

# Induction Compactmodul

## Single Cook Zones

---

### User And Installation Manual

**⚠ CAUTION:** Read the instruction before using the machine.

**⚠ WARNING:** If the surface is cracked, immediately disconnect the appliance from supply.

**Notice:** This Unit is approved for professional use only.

#### Models:

Compactmodul - 1x3.5

Compactmodul - 1x5

Compactmodul Wok - 3.5

Compactmodul Wok - 5

Compactmodul Wok - 8

Install-Line - 1x3.5

Install-Line - 1x5

Install-Line Wok - 3.5

Install-Line Wok - 5

Install-Line Wok - 8



This Manual can be find as  
PDF on  
[www.inducs.com](http://www.inducs.com)

Translation of Original Instruction – English

## READ THIS MANUAL

### Warning

Read this manual thoroughly before installing, operating, or performing maintenance on the equipment. Failure to follow instructions in this manual can cause property damage, injury or death.

This manual must always be available for reference at the place of operation.

This manual is intended for kitchen consultants, cabinet designers, fabricators, installers, owners and operators of our appliances.

Owners, consultants, fabricators and designers:

In order for the appliance to function safely and normally, you must read and understand all specific and critical requirements (such as location, ventilation, clearance) when designing the location and/or the electrical cabinet for the appliance.

Installers, operators and staff:

For your safety and safety of the others, you must follow all safety instructions during installation, operation and maintenance of the equipment.

Should you require technical assistance, call your authorized service agent or distributor.

**Always have the model and serial number available when you call.**

Your Authorized Service Company and Contact Information

Your Equipment Supplier and Contact Information

Model Number

Serial Number

Date of Installation

## **ABOUT THIS MANUAL**

Throughout this manual, the induction appliance model indicated on the cover page is referred to as **appliance, induction appliance** or **equipment**.

A period (.) is used in this manual as the decimal separator.

Original measurements are in metrics. Measurements in imperial are provided for reference.

Not ALL models, options and accessories are available in all geographical regions. Please consult your equipment supplier for the availability of the specific products in your region.

## **INSPECT THE SHIPMENT**

Thoroughly inspect the equipment upon delivery. Immediately report to the delivery carrier, any damage that occurred during transportation and request for a written inspection report from a claim adjustor.

Keep all packaging.

## **KEEP THE DELIVERY NOTE**

The delivery note attached to the shipment contains detailed information on all components. Keep the delivery note for reference.

## Safety Notices

### DEFINITIONS

#### **DANGER**

Indicates a hazardous situation that, if not avoided, will result in death or serious injury. This applies to the most extreme situations.

#### **Warning**

Indicates a hazardous situation that, if not avoided, could result in death or serious injury.

#### **Caution**

Indicates a hazardous situation that, if not avoided, could result in minor or moderate injury.









#### **Notice**

Indicates information considered important, and is used to address practices not related to physical injury. For example, messages relating to property damage.

NOTE: Indicates useful, extra information about the action you are performing.

Reference: ANSI Z535.6-2011

### SAFETY SYMBOLS AND WARNINGS ON THE APPLIANCE

|  |  |
|--|--|
|   | This symbol alerts you to a hazardous situation that WILL or COULD cause serious bodily harm or death. Be alert and implement relevant safety precautions. |
|   | <b>DANGER - HIGH VOLTAGE</b><br>This dangerous voltage warning symbol indicates a risk of electric shock and hazards from dangerous voltage.               |
|   | <b>Electromagnetic Field</b><br>This symbol warns against non-ionizing electromagnetic radiation.  |
|   | <b>Equipotential bonding</b><br>This symbol marks the terminal which has to be connected with the equipotential bonding system.                            |
|  <b>Warning</b> <br><b>RISK OF FIRE OR ELECTRIC SHOCK! DO NOT OPEN!</b><br>To reduce the risk of fire or electric shock, do not remove or open cover.<br>Refer servicing to qualified personnel.                    |  |
|  <b>DANGER</b><br>Disconnect from supply circuit before opening.  |  |
| <b>CAUTION</b>  <b>ATTENTION</b><br>DISCONNECT FROM SUPPLY CIRCUIT BEFORE OPENING<br>COUPER L'ALIMENTATION ELECTRIQUE AVANT D'OUVRIR<br>DESCONECTAR DEL CIRCUITO DE SUMINISTRO ANTES DE ABRIR<br>Αποσυνδέστε από τον καλωδιακό εξοπλισμό πριν ανοίξετε<br>إ فصل الجهاز عن الدائرة الكهربائية قبل الفتح. |  |

**DISCLAIMERS****⚠ DANGER**

Disregarding any safety instructions may cause harm to people, the surroundings, and the equipment. The manufacturer and/or authorized representative are not responsible for any damages or personal injury caused by failure to observe any safety instructions. Risks involved when disregarding safety instructions include, but not limiting to:

- Death or injury caused by electric shock.
- Burn injury caused by contacting hot cooking surface, cookware, or oil and grease.
- Damage to the equipment caused by using unsuitable cookware.

**⚠ DANGER**

Do not install or operate equipment and/or accessories that have been misused, abused, neglected, damaged, or altered from that of original manufactured specifications.

**⚠ DANGER**

Contact the manufacturer if you intend to make any changes on the equipment. For safety reasons, always use genuine parts and accessories approved by the manufacturer or authorized representative. Refer to the warranty documents for your equipment.

**⚠ DANGER**

Owners and operators are cautioned that maintenance and repairs must be performed by an authorized service agent using only genuine replacement parts. The manufacturer will have no obligation with respect to any product that has been improperly installed, adjusted, operated or not maintained in accordance with national and local codes and/or installation instructions provided with the product or any product that has its serial number defaced, obliterated or removed, and/or which has been modified or repaired using unauthorized parts or by unauthorized service agents.

**⚠ DANGER**

Improper installation, adjustment, alteration, service, or maintenance of this appliance or installation of a damaged appliance can result in DEATH, INJURY, EQUIPMENT DAMAGE, and void the warranty.

**⚠ DANGER**

All power connections and fixtures must be maintained in accordance with local and national codes.

**⚠ Warning**

Do not store or use gasoline or other flammable vapors or liquids in the vicinity of this or any other appliance. Never use flammable oil soaked cloths or combustible cleaning solutions for cleaning.

**⚠ Warning**

This appliance is not intended for use by persons (including children) with reduced physical, sensory or mental capabilities, or lack of experience and knowledge, unless they have been given supervision concerning use of the appliance by a person responsible for their safety. Do not allow children to play with this appliance.

**⚠ Warning**

This product contains chemical known to the State of California to cause cancer and/or birth defects or other reproductive harm. Operation, installation, and servicing of this product could expose you to airborne particles of glass-wool or ceramic fibers, crystalline silica, and/or carbon monoxide. Inhalation of airborne particles of glass-wool or ceramic fibers is known to the State of California to cause cancer. Inhalation of carbon monoxide is known to the State of California to cause birth defects or other reproductive harm.

**⚠ Warning**

Authorized Service Representatives are obligated to follow industry standard safety procedures, including, but not limited to, local/national regulations for disconnection / lock out / tag out procedures for all utilities including electric, gas, water and steam.

**Notice**

This appliance is not approved or authorized for home or residential use, but is intended for commercial applications only. The manufacturer and/or authorized representative will not provide service, warranty, maintenance or support of any kind other than in commercial applications.

**Notice**

Routine adjustments and maintenance procedures outlined in this manual are not covered by the warranty.

NOTE: Proper installation, care and maintenance are essential for maximum performance and trouble-free operation of your equipment. Visit our website for manual updates, translations, or contact information for service agents in your area.

**CORRECT DISPOSAL OF THIS PRODUCT**



This marking shown on the product indicates that the product should not be disposed as household waste or regular commercial waste. Instead it shall be

handed over to the applicable collection point for the recycling of electrical and electronic equipment. By ensuring this product is disposed correctly, you will help prevent potential harm to the environment or human health, which could otherwise be caused by inappropriate waste handling of this product.

For more detailed information regarding recycling of the product, please contact your local city office or your waste disposal service.

NOTE: The appliance is built with common electrical, electromechanical and electronic parts. No batteries are used.

NOTE: The owner and operator are responsible for the proper and safe disposal of the appliance.

**Important**

**Additional Safety Notices are stated in the relevant sections throughout the manual.**



# Table of Contents

---

## Safety Notices

|  |   |
|--|---|
| Definitions .....                                  | 4 |
| Safety symbols and Warnings on the Appliance ..... | 4 |
| Disclaimers .....                                  | 5 |
| Correct Disposal of this Product .....             | 6 |

## Table of Contents

### Section 1

#### General Information

|   |           |
|---|-----------|
| <b>Description of Product .....</b>         | <b>11</b> |
| <b>Application .....</b>                    | <b>11</b> |
| <b>Compliances .....</b>                    | <b>11</b> |
| <b>Serial Plate Location .....</b>          | <b>11</b> |
| <b>Model number and serial number .....</b> | <b>12</b> |
| <b>Product overview .....</b>               | <b>12</b> |
| Generators .....                            | 12        |
| Control Unit .....                          | 13        |
| Sets .....                                  | 13        |

### Section 2

#### Installation

|   |           |
|---|-----------|
| Installation Safety—Disclaimer .....  | 15        |
| Installation Safety—Clearance and Ventilation .....                                     | 15        |
| Installation Safety—Electrical .....  | 16        |
| Personal Protection .....   | 17        |
| <b>Scope of delivery .....</b>  | <b>18</b> |
| Available Options .....   | 18        |
| <b>Specifications .....</b>   | <b>20</b> |
| Dimensions: Compactmodul 1x3.5, Compactmodul 1x5 .....                                  | 20        |
| Dimensions: Compactmodul Wok 1x3.5, Compactmodul Wok 1x5,<br>Compactmodul Wok 1x8 ..... | 21        |
| Dimensions: Install-Line 1x3.5, Install-Line 1x5 .....                                  | 22        |
| Dimensions: Install-Line WOK 1x3.5, Install-Line WOK 1x5, Install-Line WOK<br>1x8 ..... | 23        |
| Dimension: Operation with power controller and LED .....                                | 24        |
| Dimension: Flex-Operation Unit Single with front panel .....                            | 25        |
| Dimension: Flex-Operation Unit Single without Metal Front .....                         | 26        |
| <b>Electrical Specifications .....</b>  | <b>27</b> |
| Electrical Cables .....   | 27        |
| Installation Clearance .....  | 27        |
| Operating Conditions .....  | 27        |
| Weights .....   | 27        |
| <b>Installation Instructions Compactmodul .....</b>                                     | <b>28</b> |



---

|  |           |
|--|-----------|
| <b>Installation Instructions Install-Line .....</b>        | <b>28</b> |
| <b>Ventilation Requirements .....</b>                      | <b>29</b> |
| Example ventilation with ventilation kit.....              | 29        |
| <b>Air supply .....</b>                                    | <b>29</b> |
| <b>Air exhaust .....</b>                                   | <b>29</b> |
| Commissioning.....   | 30        |
| <b>Function Test .....</b>                                 | <b>30</b> |
| <br>   |           |
| <b>Section 3</b>   |           |
| <b>Operation</b>   |           |
| Operation Safety—Disclaimer .....                          | 31        |
| Operation Safety—Personal Protection .....                 | 32        |
| <b>Important Rules—Operation and Maintenance .....</b>     | <b>34</b> |
| <b>Proper Induction Cookware.....</b>                      | <b>35</b> |
| Condition .....  | 35        |
| Material.....  | 35        |
| Boil Test.....   | 36        |
| Size of Pan.....   | 36        |
| <b>Placing Pan On A Cooking Zone .....</b>                 | <b>36</b> |
| <b>Rotary power switch .....</b>                           | <b>38</b> |
| <b>Flex-Operation Unit Single Display (Overview) .....</b> | <b>39</b> |
| <b>Control .....</b>                                       | <b>40</b> |
| Turn unit on.....  | 40        |
| LED Ring .....   | 40        |
| Switching Between cooking and holding modes.....           | 40        |
| Setting Power Level (1 to 12) and Lock/Unlock .....        | 40        |
| Selecting hold Temperature and Lock/Unlock.....            | 40        |
| Setting the Timer.....                                     | 41        |
| Turning Unit off .....                                     | 41        |
| <b>Additional Settings.....</b>                            | <b>41</b> |
| <b>Automatic Pan Detection, No Pan No Heat.....</b>        | <b>42</b> |
| <b>When the application is not in use .....</b>            | <b>42</b> |
| <b>Decommissioning .....</b>                               | <b>42</b> |
| <br>   |           |
| <b>Section 4</b>   |           |
| <b>Maintenance</b>   |           |
| Maintenance Safety—Disclaimer.....                         | 43        |
| Dangerous Electrical Voltage.....                          | 43        |
| Maintenance Safety—Cleaning.....                           | 43        |
| Personal Protection .....                                  | 44        |
| <b>Daily Cleaning and Maintenance.....</b>                 | <b>45</b> |
| Glass Cleaning .....                                       | 45        |
| Visual Inspection of Silicone Seal .....                   | 45        |
| <b>Weekly Cleaning and Maintenance .....</b>               | <b>45</b> |
| <b>Yearly Maintenance .....</b>                            | <b>45</b> |

**Section 5**  
**Troubleshooting**

|  |           |
|--|-----------|
| Dangerous Electrical Voltage.....                                  | 46        |
| <b>Common Problems .....</b>                                       | <b>46</b> |
| <b>Symptoms.....</b>   | <b>46</b> |
| <b>Boil Test.....</b>  | <b>47</b> |
| <b>Avoiding dangers in case of accidents or malfunctions .....</b> | <b>47</b> |
| <b>Troubleshooting Without Error Code .....</b>                    | <b>48</b> |
| <b>Troubleshooting — Error Code.....</b>                           | <b>50</b> |

# Section 1

## General Information

---

### Description of Product

Built with a robust construction, our induction appliances are compact and powerful with the revolutionary RTCSmp® Technology (Realtime Temperature Control System).

The RTCSmp® Technology monitors continuously in real time, the energy supply, temperature of the cook zone and the state of the components such as the induction coil. This monitoring system ensures the most efficient energy transfer, as well as maximizes safety:

- Safety functions such as Pan Detection and Boil Dry Protection are therefore guaranteed.
- The appliance starts heating only when a pan is placed in the cook zone.
- When a malfunction occurs, the integrated fault diagnostic system reports the malfunction instantly.

### Application

The Compactmodul induction units are designed as compact units for installation in a closed stove or counter.

Many applications throughout the day with your appliance are possible, such as cooking, warming up, keeping warm, and roasting of food:

- Thanks to RTCSmp temperature control happens instantly.
- With inductive energy transmission, your cookware can be heated very quickly.
- High power is possible for braising application and quick sauté.
- High power also means you can heat up a bigger pot quickly.

NOTE: To guarantee the reliability and performance of the appliance, you must use the recommended types and sizes of pans with the appliance. See section 3 Operation.

### Compliances



The units comply the latest Norms:

#### Europe models

- EN 55014-1
- EN 55014-2
- EN 60529
- EN 62233 (EMC/EMV)
- EN 60335-1
- EN 60335-2-36
- EN 61000-3-11
- EN 61000-3-12

### Serial Plate Location

The serial plate is located on the bottom panel of the unit. It specifies the model number, serial number, and electrical specifications of the appliance.

## Model number and serial number

The model and serial numbers are located on the nameplate. This manual applies only to the models listed on the front of this manual.

### READING THE MODEL NUMBER

[Model Name] - [Power] [Coil Type] - [Nominal Voltage]

| Model Name       | Power   | Coil Type                            | Nominal Voltage                          |
|------------------|---|--------------------------------------|--|
| Compactmodul     | 1x3.5 = 1 cook zones; 3.5kW<br>1x5 = 1 cook zones; 5kW                      | R = Round                            | 230 = 1 x 230-240V<br>400 = 3 x 380-440V |
| Compactmodul Wok | 3.5 = 1 cook zones; 3.5kW<br>5 = 1 cook zones; 5kW<br>8 = 1 cook zones; 8kW |                                      | 230 = 1 x 230-240V<br>400 = 3 x 380-440V |
| Install-Line     | 1 = 1 cook zones; 3.5kW per zone<br>1 = 1 cook zones; 5kW per zone          | R = Round<br>F = Full area induction | 230 = 1 x 230-240V<br>400 = 3 x 380-440V |
| Install-Line Wok | 3.5 = 1 cook zones; 3.5kW<br>5 = 1 cook zones; 5kW<br>8 = 1 cook zones; 8kW |                                      | 230 = 1 x 230-240V<br>400 = 3 x 380-440V |

## Product overview

### GENERATORS

| Available models                 | Power per Hob | Glass Size        | Coil Type           | Nominal Voltage |
|----------------------------------|---------------|-------------------|---------------------|-----------------|
| Compactmodul - 1x3.5 R - 230     | 1 x 3.5kW     | 360 x 360 mm      | Round               | 1 x 230-240V    |
| Compactmodul - 1x5 R - 400       | 1 x 5kW       | 360 x 360 mm      | Round               | 3 x 380-440V    |
| Compactmodul Wok - 3.5 - 230-240 | 1 x 3.5kW     | Diameter = 300 mm | Wok                 | 1 x 230-240V    |
| Compactmodul Wok - 5 - 380-440   | 1 x 5kW       | Diameter = 300 mm | Wok                 | 3 x 380-440V    |
| Compactmodul Wok - 8 - 380-440   | 1 x 8kW       | Diameter = 300 mm | Wok                 | 3 x 380-440V    |
| Install-Line - 1x3.5 R - 230     | 1 x 3.5kW     | 320 x 320 mm      | Round               | 1 x 230-240V    |
| Install-Line - 1x5 R - 400       | 1 x 5kW       | 320 x 320 mm      | Round               | 3 x 380-440V    |
| Install-Line - 1x5 F - 400       | 1 x 5kW       | 320 x 320 mm      | Full area induction | 3 x 380-440V    |
| Install-Line Wok - 3.5 - 230     | 2 x 3.5kW     | Diameter = 300 mm | Wok                 | 1 x 230-240V    |
| Install-Line Wok - 5 - 400       | 2 x 3.5kW     | Diameter = 300 mm | Wok                 | 3 x 380-440V    |
| Install-Line Wok - 8 - 400       | 2 x 5kW       | Diameter = 300 mm | Wok                 | 3 x 380-440V    |

## CONTROL UNIT

| Available models                    | Description  |
|-------------------------------------|--|
| Operation unit Compactmodul         | This operation consists of a rotary switch which lock in the 0 position and an LED operating indicator. 1 units is required for one Compactmodul Single / Install-Line Single.                         |
| Tap-Operation (with front panel)    | This operation consists of 1 knob and a display unit with front panel, for overlying mounting. Only 1 unit is required for one Compactmodul Single / Install-Line Single.                              |
| Tap-Operation (without front panel) | This operation consists of 1 knob and a display unit without front panel, for direct integration into a stove construction. Only 1 unit is required for one Compactmodul Single / Install-Line Single. |

## SETS

| Available sets                                       | Description  |
|--|--|
| Ventilation set Compactmodul and Install-Line Single | Used to improve ventilation in the counter or stove. |



## Section 2 Installation

### INSTALLATION SAFETY—DISCLAIMER

#### **⚠ DANGER**

Installation must be carried out by registered installation contractors only.

The contractors are responsible for interpreting all instructions correctly and performing the installation in compliance with all applicable national and local regulations.

The warning signs and serial plates on the equipment must strictly be followed.

#### **⚠ Warning**

This equipment is intended for indoor use only. Do not install or operate this equipment in outdoor areas.

#### **⚠ Warning**

Before installation, make sure that the load capacity of the stove or counter is sufficient. It is important to ensure that the ceramic glass is mounted flush with the stove top sheet. Lateral impacts on the ceramic glass can quickly lead to a bursting of the ceramic glass.

#### **⚠ Caution**

Consultants, fabricators and designers must consult their induction suppliers when designing an appropriate support structure and device clearance and the installation.

#### **Notice**

The Ceran® glass must be bonded using silicone that is compatible with foodstuff.

#### **Notice**

Induction equipment that is not installed correctly will have warranty voided.

### INSTALLATION SAFETY—CLEARANCE AND VENTILATION

#### **⚠ DANGER**

#### **Risk of Fire or Shock or Equipment Failure**

All minimum clearances must be maintained. Air intake vents and exhaust vents must not be blocked or be restricted.

#### **⚠ Caution**

This equipment must only be operated under an approved ventilation system in accordance with all applicable national and local regulations. Exceptions may apply.

#### **Notice**

**The maximum ambient temperature for the induction appliance to operate must not exceed 40°C [104°F].**

**Failure to provide adequate ventilation will cause the appliance to overheat, to reduce power, or to shutdown.**

#### **Notice**

The induction unit must not be installed above an oven or other sources of heat.

NOTE: Always maintain enough space between and around the equipment for maintenance and service.

**INSTALLATION SAFETY—ELECTRICAL****⚠ DANGER**

Installation must be carried out by registered installation contractors only.

The contractors are responsible for interpreting all instructions correctly and performing the installation in compliance with all applicable national and local regulations.

The warning signs and serial plates on the equipment must strictly be followed.

**⚠ DANGER**

The device must be protected and connected with an all-pole circuit breaker which ensures complete separation under over voltage category III.

**⚠ DANGER**

The devices must be installed in such a way that the device connections are protected from contact and can only be accessed with a tool.

**⚠ Warning**

This equipment is intended for indoor use only. Do not install or operate this equipment in outdoor areas.

**⚠ Warning**

The device must be operated with an all-pole circuit breaker or disconnecter of over voltage category III.

**⚠ Warning**

**CE Induction Appliance only:** If ground fault current protective switches are used, they must be designed for a minimum fault current of 30mA, Type B or B+.

**Notice**

Ensure the supply voltage and the line current match the specifications given on the serial plate affixed to the appliance. Wrong voltage will damage the appliance. A stable power supply must be provided.

**Notice**

Always refer to the serial plate on the appliance to verify the electrical data. When the data listed on the serial plate is different than that listed in this manual, contact the manufacturer or the authorized representative.

**Notice**

All cables must be routed, protected and tension free.



**PERSONAL PROTECTION****⚠ DANGER**

All utilities (gas, electric, water and steam) must be OFF to all equipment and locked out of operation according to national/regional regulations, as well as company approved practices during installation, maintenance and servicing. Always allow appliance to cool.

**⚠ DANGER**

Use appropriate safety equipment during installation, maintenance and servicing.

**⚠ DANGER**

Never stand, sit, or lean on the equipment! They are not designed to hold the weight of an adult, and may collapse or tip if misused in this manner.

**⚠ DANGER**

To avoid cardiac pacemaker malfunction, consult your physician or pacemaker manufacture about effects of electromagnetic field on your pacemaker.

**⚠ DANGER**

Replace defective power cables immediately by an authorized service agency.

**⚠ Warning**

Markings and warning labels mounted directly on the equipment must be observed at all times and kept in a fully legible condition.

**⚠ Warning**

Risk of burns from high temperatures. You may get burnt if you touch any of the parts during operation. Surfaces close to the cooking area including side panels may get hot enough to burn skin. Use extreme caution to avoid coming in contact with hot surfaces or hot grease. Wear personal protective equipment.

**⚠ Caution**

Use caution when handling the device. The device may have sharp metal edges.

## Scope of delivery

Choose from the various Compactmodul options to ideally fit your built-in situation and application.

### AVAILABLE OPTIONS

#### Simple rotary switch

If you choose this service, be aware that you need two rotary switches. The rotary switch is enclosed with a 1m cable.

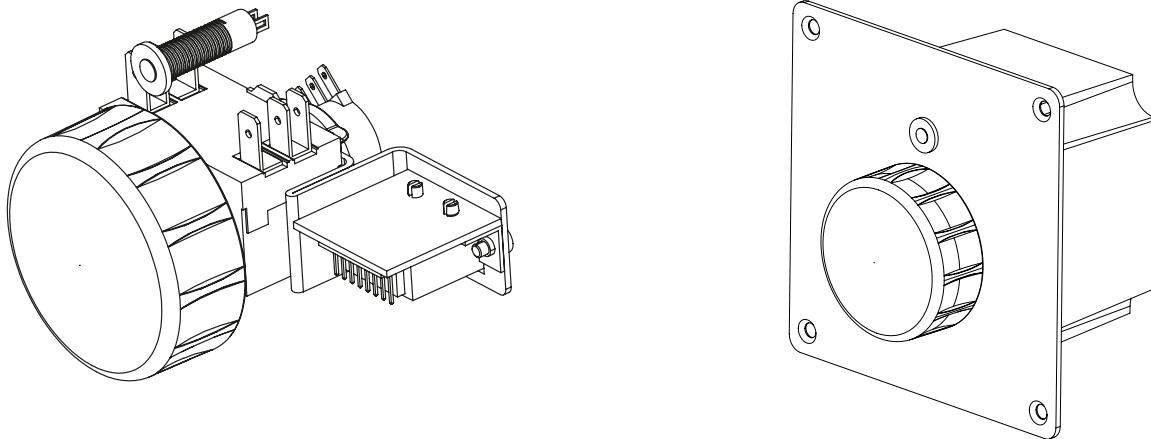

#### Tap-Operation with display and two rotary switches

Operation with display allows you to use the following additional functions: warm-holding, timer function, individual power reduction, error code display and lock function.

The operation is enclosed with a 1m long connection cable.

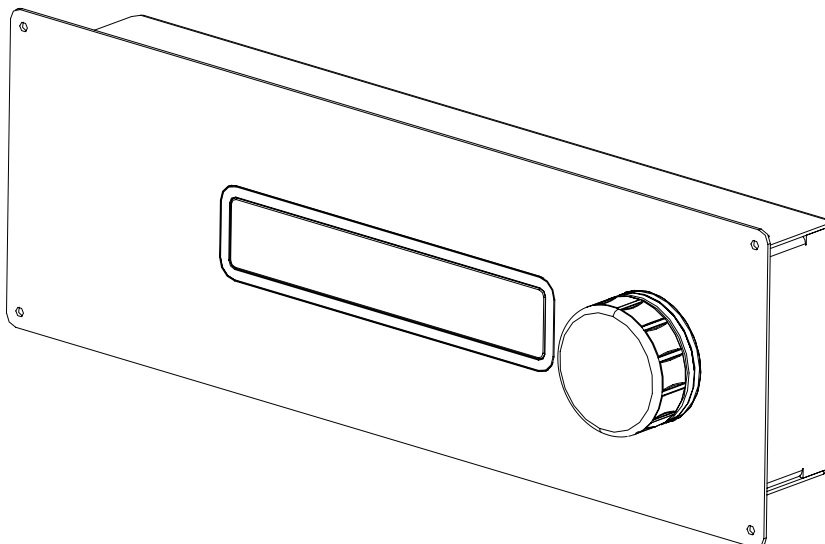

### Ventilation set

The ventilation set is used to optimize cooling. Included in it is a suction sleeve, grease filter frame and grease filter, ventilation pipe, pipe clamp and mounting hardware.

3 options are available

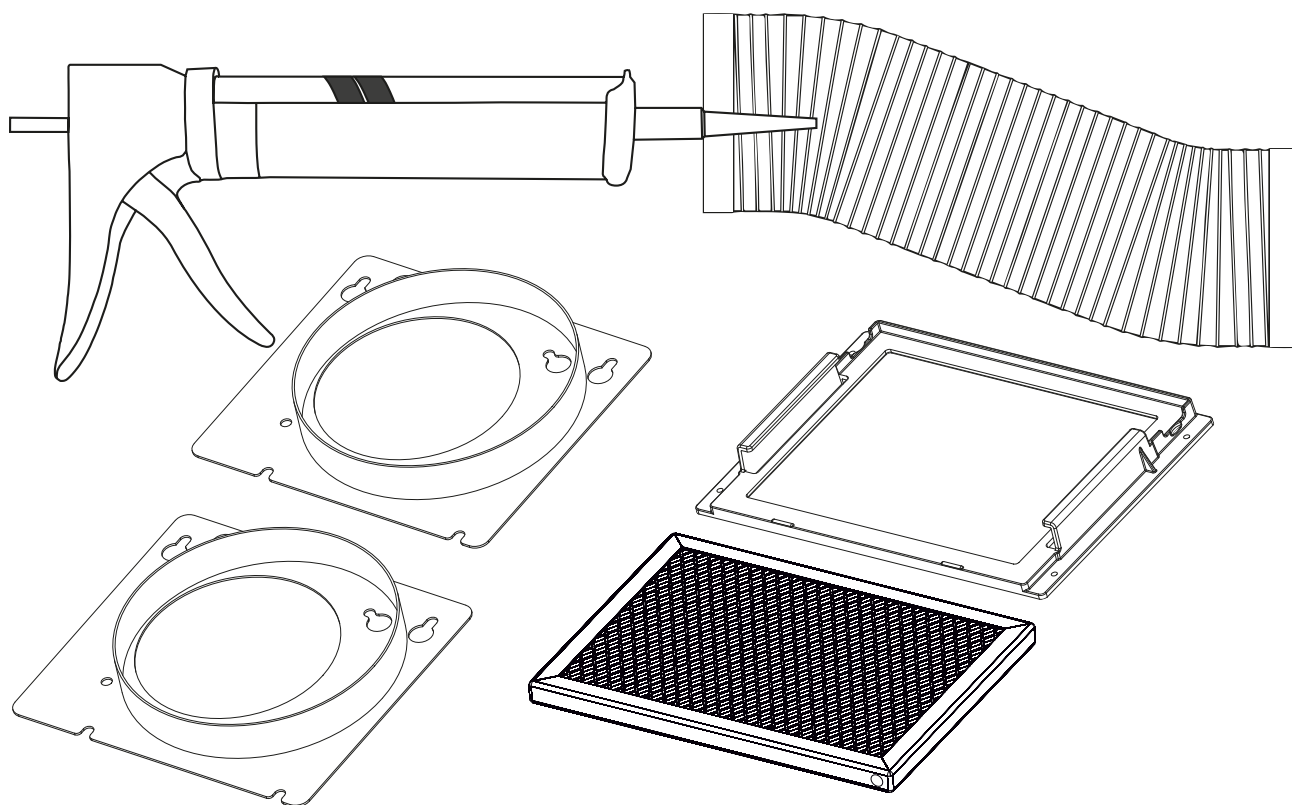

## Specifications

### DIMENSIONS: COMPACTMODUL 1X3.5, COMPACTMODUL 1X5

The maximum counter top thickness is 30mm [1.2"]. The minimal air Supply and air exhaust opening must be 6500mm<sup>2</sup> [10.08in<sup>2</sup>]

Dimensions are specified in mm [inches].

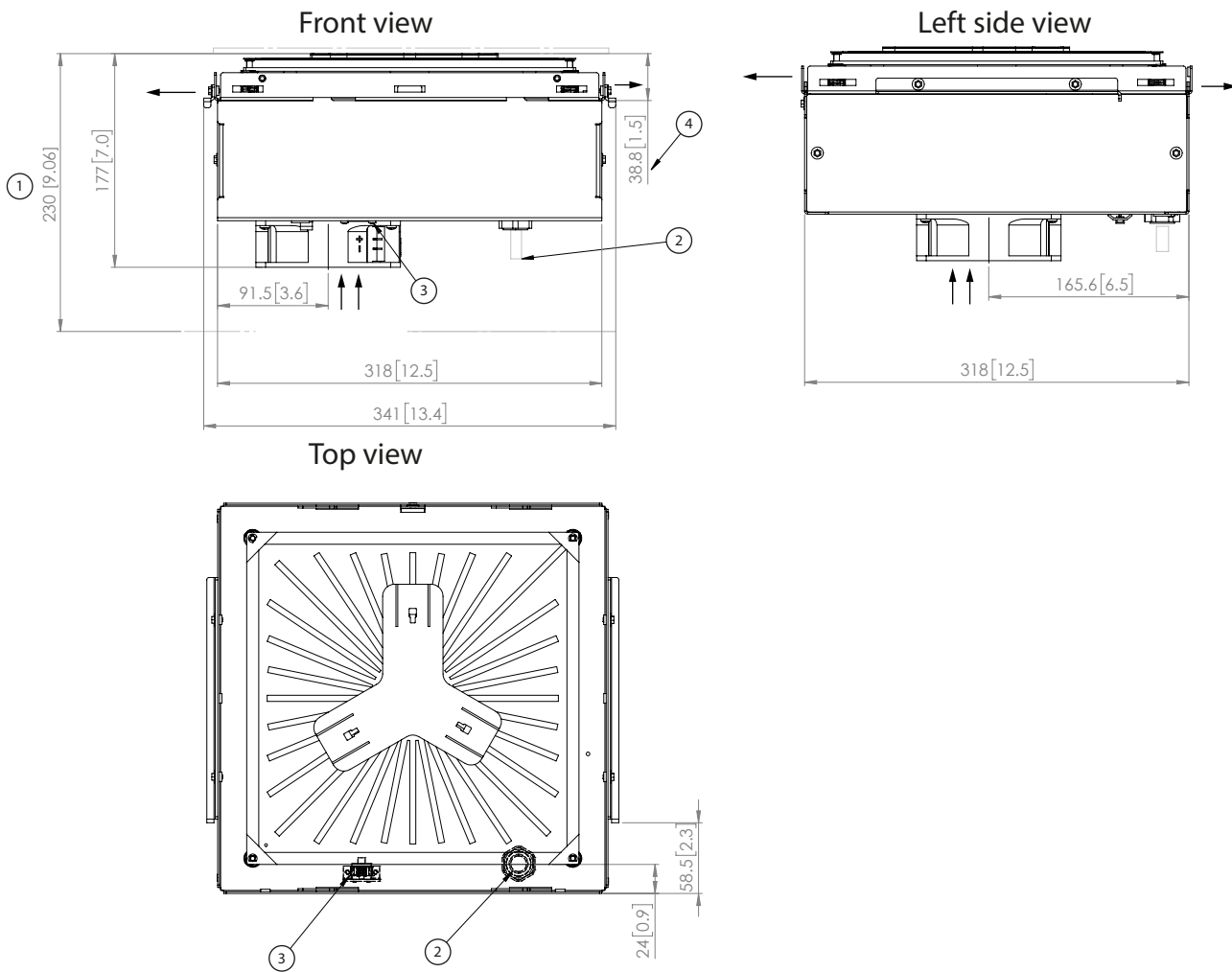

|   |   |
|---|---|
| ➔ | Indicates the direction of airflow        |
| 1 | Minimum installation height 230mm [9.06"] |
| 2 | Main cable                                |
| 3 | RJ-45 connection for operation unit       |
| 4 | Distance to Ceran                         |

**DIMENSIONS: COMPACTMODUL WOK 3.5, COMPACTMODUL WOK 5, COMPACTMODUL WOK 8**

The maximum counter top thickness is 30mm [1.2"]. The minimal air Supply and air exhaust opening must be 6500mm<sup>2</sup> [10.08in<sup>2</sup>]

Dimensions are specified in mm [inches].

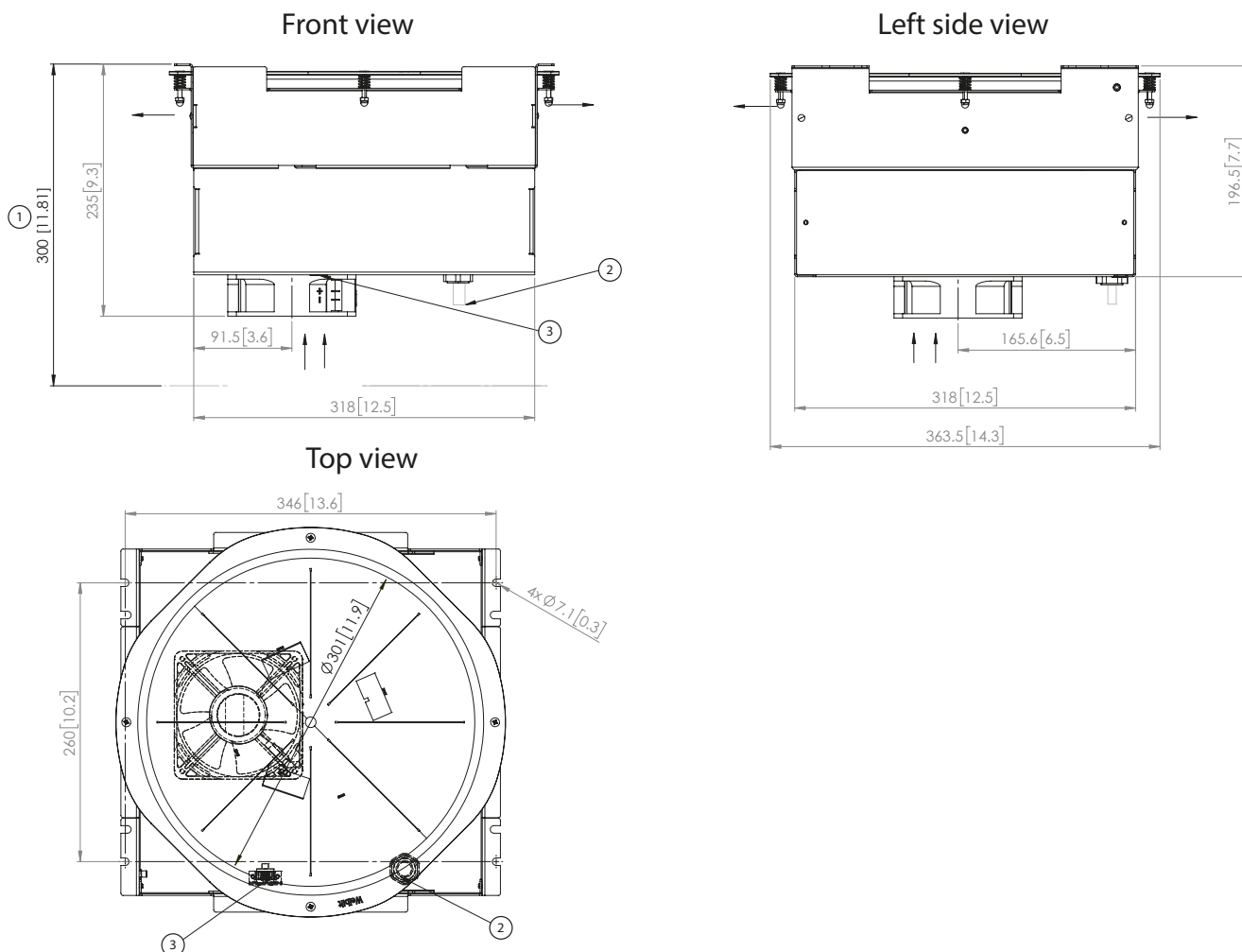

|          |   |
|----------|---|
| ➔        | Indicates the direction of airflow        |
| <b>1</b> | Minimum installtion height 300mm [11.81"] |
| <b>2</b> | Main cable                                |
| <b>3</b> | RJ-45 connection for operation unit       |

**DIMENSIONS: INSTALL-LINE 1X3.5, INSTALL-LINE 1X5**

The cut-out in the stove top must be at least 350 x 350mm [13.78" x 13.78"] for 1 Compactmodul. The minimal air Supply and air exhaust opening must be 6500mm<sup>2</sup> [10.08in<sup>2</sup>]

Dimensions are specified in mm [inches].

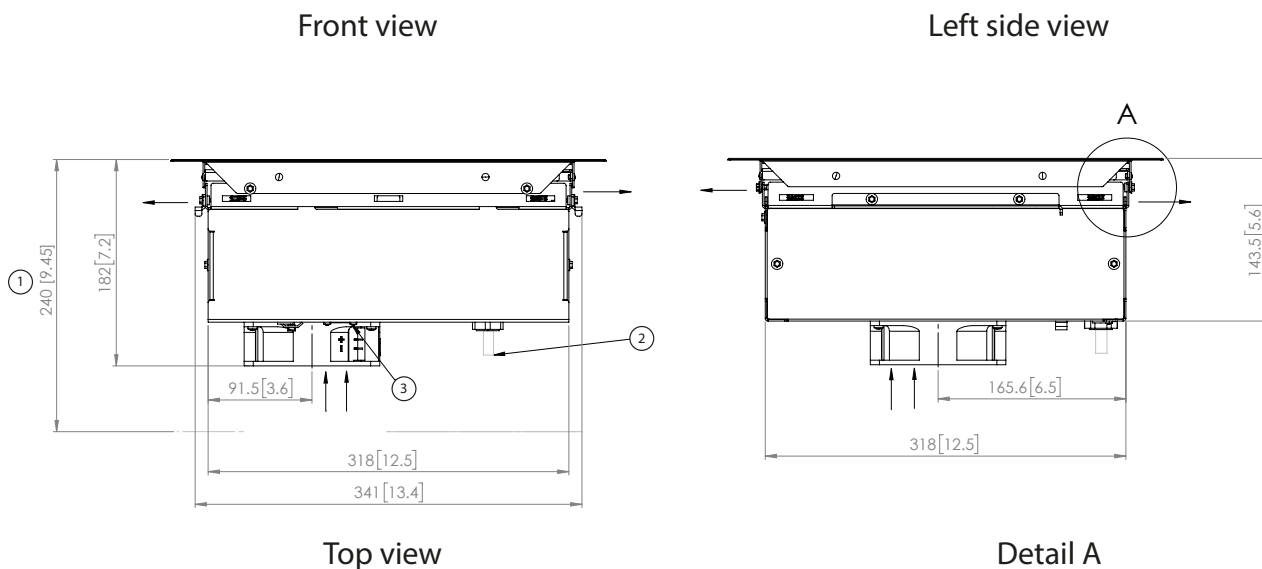

➔ Indicates the direction of airflow

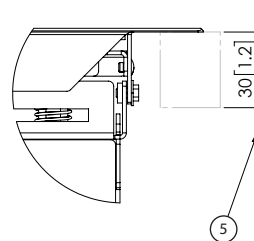
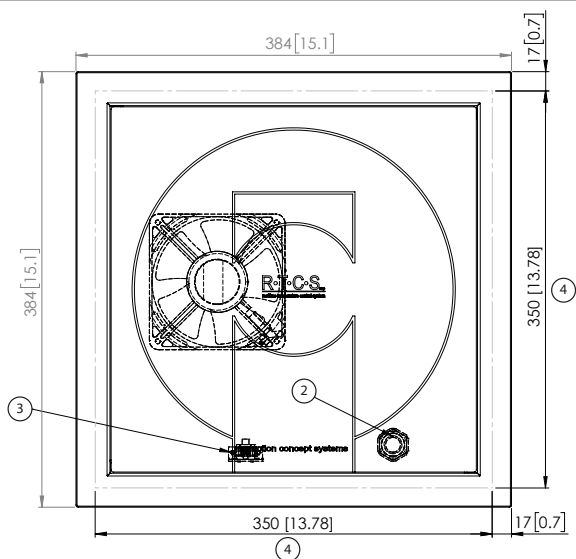

|   |   |
|---|---|
| 1 | Minimum installation height 240mm [7.87"] |
| 2 | Main cable                                |
| 3 | RJ-45 connection for operation unit       |
| 4 | Cut-out of the work top                   |
| 5 | Countertop maximal thickness 30mm [1.2"]  |

**DIMENSIONS: INSTALL-LINE WOK 3.5, INSTALL-LINE WOK 5, INSTALL-LINE WOK 8**

The cut-out in the stove top must be at least 356 x 356mm [14.02" x 14.02"] for 1 Compactmodul. The minimal air Supply and air exhaust opening must be 6500mm<sup>2</sup> [10.08in<sup>2</sup>]. Dimensions are specified in mm [inches].

Front view

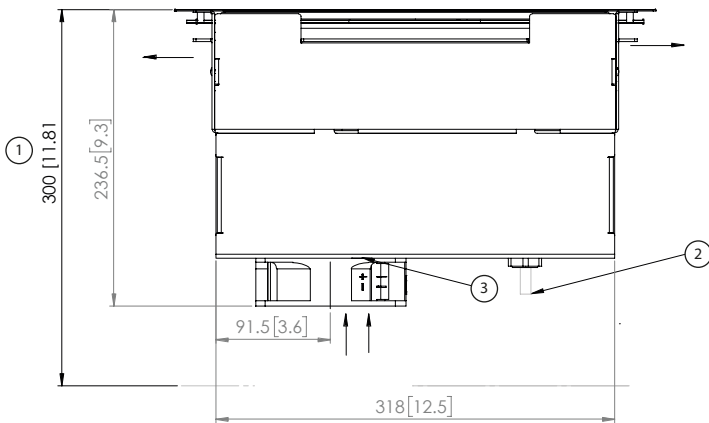

Left side view

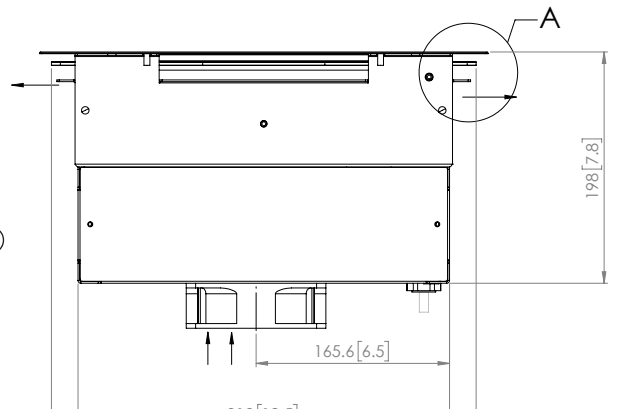

Top view

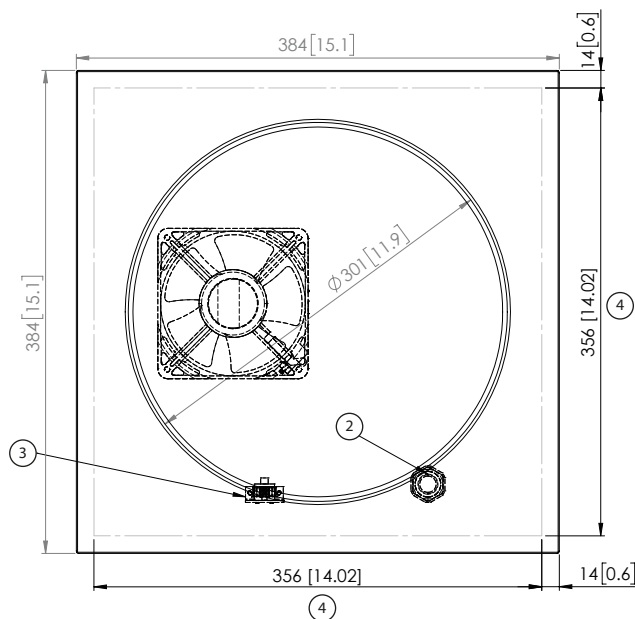

Detail A

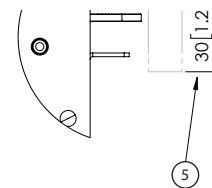

|   |  |
|---|--|
| ➔ | Indicates the direction of airflow                   |
| 1 | Minimum installation height                          |
| 2 | Main cable   |
| 3 | RJ-45 connection for operation unit                  |
| 4 | Cut-out of the work top 356 x 356mm [14.02 x 14.02"] |
| 5 | Counter top maximal thickness 30mm [1.2"]            |

**DIMENSION: OPERATION WITH POWER CONTROLLER AND LED**

For the intended mounting on a panel, the required hole pattern for the power controller and the LED must be considered. The length of the RJ-45 cable to connect the Control unit to the generator is 1m.

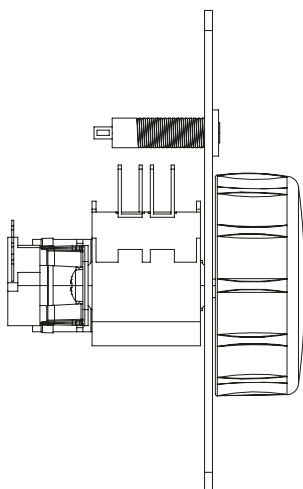
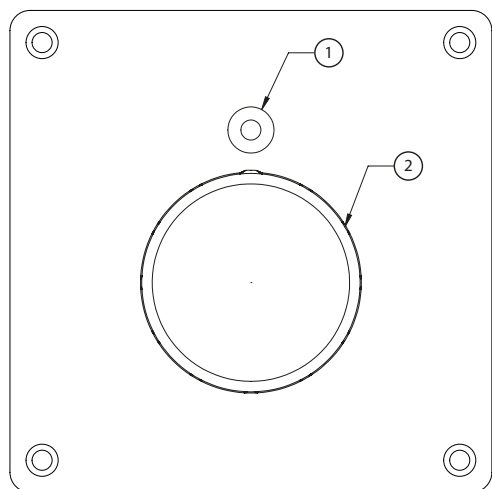

**Cut-out**

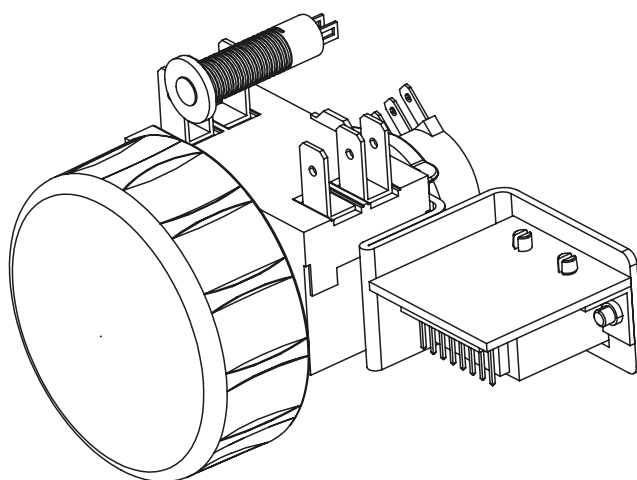
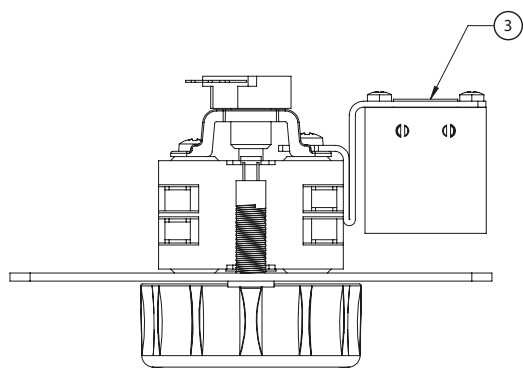
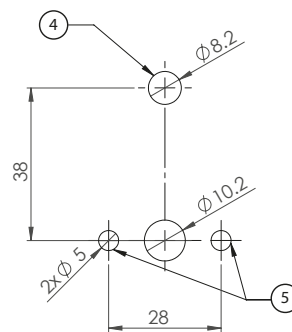

|   |   |
|---|---|
| 1 | LED   |
| 2 | Rotary switch                               |
| 3 | RJ45 Socket                                 |
| 4 | Hole for LED                                |
| 5 | Holes for attachment from the rotary switch |



**DIMENSION: TAP-OPERATION SINGLE WITH FRONT PANEL**

The Tap-Operation allows you to use warm holding and timer function. The length of the connecting cable for connecting the operating unit to the generator is 1m.

Panel cut Out: 380mm x 115mm [15" x 4.25"]

Installation depth: 115mm [3.35"]

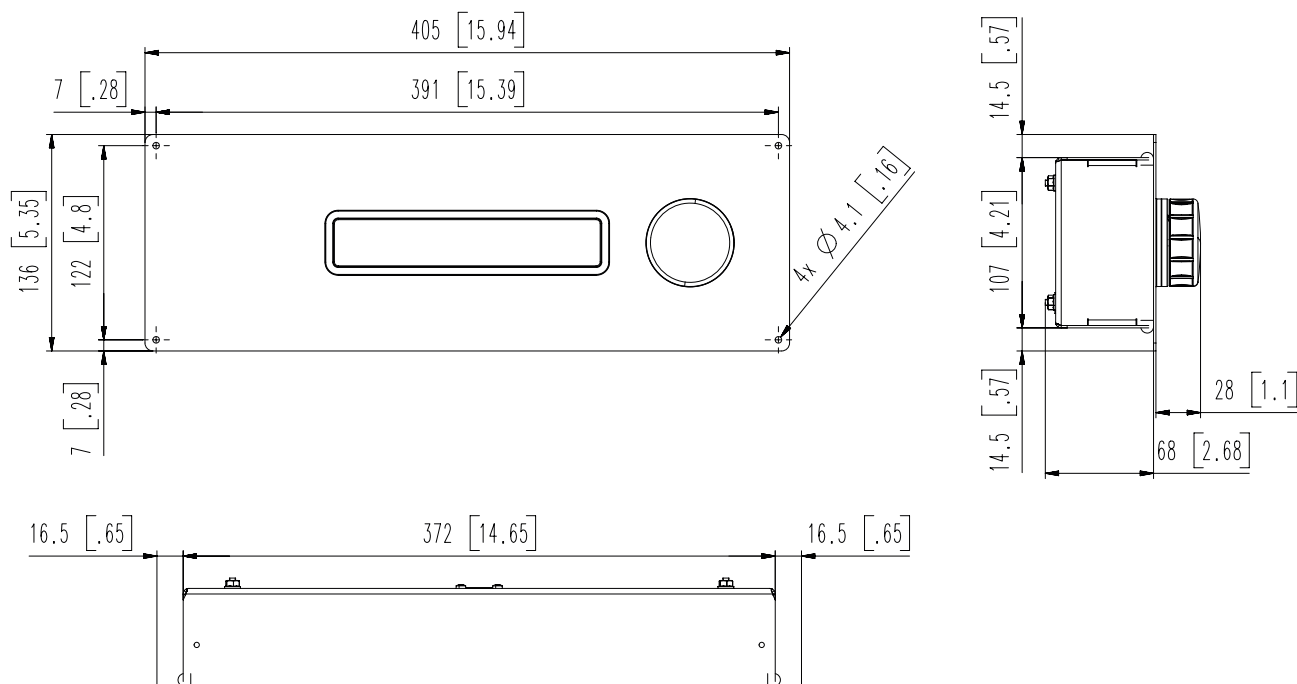

**DIMENSION: TAP-OPERATION SINGLE WITHOUT METAL FRONT**

The Tap-Operation allows you to use warm holding and timer function. This option is meant to directly integrate the operation in your counter or kitchen range. The length of the connecting cable for connecting the operating unit to the generator is 1m.

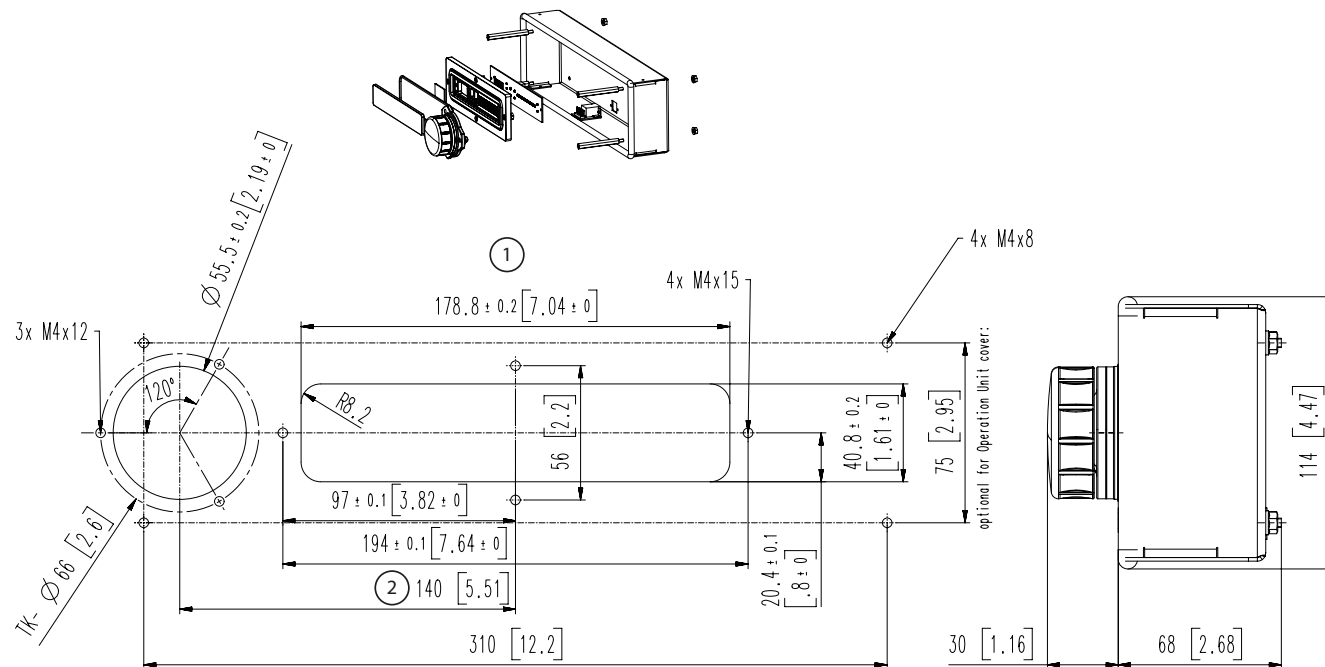

|   |   |
|---|---|
| 1 | Mounting cut-out (rear view)            |
| 2 | Max. Distance from operation to display |

**ELECTRICAL SPECIFICATIONS**

| <b>Model</b>                 | <b>Power / Current</b> | <b>Voltage / Phases</b> |
|------------------------------|------------------------|-------------------------|
| Compactmodul - 1x3.5 R - 230 | 3.5kW / 16A            | 230V - 240V / 1Φ        |
| Compactmodul - 1x5 R - 400   | 5kW / 8A               | 380V - 240V / 3Φ        |
| Compactmodul Wok - 3.5 - 230 | 3.5kW / 16A            | 230V - 240V / 1Φ        |
| Compactmodul Wok - 5 - 400   | 5kW / 8A               | 380V - 240V / 3Φ        |
| Compactmodul Wok - 8 - 400   | 8kW / 12A              | 380V - 240V / 3Φ        |
| Install-Line - 1x3.5 R - 230 | 3.5kW / 16A            | 230V - 240V / 1Φ        |
| Install-Line - 1x5 R - 400   | 5kW / 8A               | 380V - 240V / 3Φ        |
| Install-Line Wok - 3.5 - 230 | 3.5kW / 16A            | 230V - 240V / 1Φ        |
| Install-Line Wok - 5 - 400   | 5kW / 8A               | 380V - 240V / 3Φ        |
| Install-Line Wok - 8 - 400   | 8kW / 12A              | 380V - 240V / 3Φ        |

**ELECTRICAL CABLES**

Power cords are not included. The cable for operation is enclosed with the operation unit. The cables must be routed so that they will not mechanically damaged.

**INSTALLATION CLEARANCE****Notice**

The orientation of each appliance in a parallel configuration will affect the ventilation requirements. Ensure the final installation meets all operating and ventilation requirements.

**OPERATING CONDITIONS**

For the appliance to function properly, the following conditions must be maintained.

|   |  |
|---|--|
| Maximum Tolerance of the Nominal Supply Voltage | +6 /-10 %  |
| Supply frequency                                | 50/60 Hz   |
| Ingress Protection class                        | 12 cm [5"]   |
| Minimal Diameter of Induction Pan               | In Storage, -20°C to +70°C [-4°F to +158°F]<br>In Operation, +5°C to +40°C [+41°F to +104°F] |
| Maximum Relative Air Humidity                   | In Storage, 10% to 90%<br>In Operation, 30% to 90%   |

**WEIGHTS**

| <b>Model</b>                  | <b>Net Weight</b> |           |
|-------------------------------|-------------------|-----------|
|                               | <b>kg</b>         | <b>lb</b> |
| <b>Compactmodul - 1x3.5</b>   | 6                 | 13.5      |
| <b>Compactmodul - 1x5</b>     | 7                 | 15.5      |
| <b>Compactmodul Wok - 3.5</b> | 5.5               | 12.5      |
| <b>Compactmodul Wok - 5</b>   | 6                 | 13.5      |
| <b>Compactmodul Wok - 8</b>   | 6.5               | 14.5      |
| <b>Install-Line - 1x3.5</b>   | 8                 | 17.5      |
| <b>Install-Line - 1x5</b>     | 9                 | 20        |
| <b>Install-Line Wok - 3.5</b> | 7.5               | 16.5      |
| <b>Install-Line Wok - 5</b>   | 8                 | 17.5      |
| <b>Install-Line Wok - 8</b>   | 8.5               | 18        |

## Installation Instructions Compactmodul



Read and understand all installation safety instructions regarding Clearance and Ventilation at the beginning of this chapter.

- The 39mm clearance, +/- 1mm, from the underside of the coil carrier to the ceramic glass must be adhered to (see the drawing).
- The straps on the guide rails enable correct position below the ceran glass of the induction unit. The final position of the unit is achieved once the straps are engaged in the indentation of the support rails.
- For installation and as a support of the induction device, the guide rails are provided.
- The openings in the coil carrier sheet below the coils must not be closed.
- Components made from steel in the vicinity of the coils must not be magnetic.
- If two coil carrier sheets are installed in the same frame, a partitioning plate made from non-magnetic steel must be installed between the coil carrier sheets.
- The Compactmodul must be easily accessible for installation and removal.
- The Ceran® glass must be bonded using silicone that is compatible with foodstuff.
- The control switches must not be blocked.
- Keep flammable substances, vapors or liquids away from the induction unit.
- When installing, pay attention to the position of the connections. Otherwise, it may be that the cooking zones do not match the operation. (Connections always on the left side or in front).

## Installation Instructions Install-Line



Read and understand all installation safety instructions regarding Clearance and Ventilation at the beginning of this chapter.

- The openings in the coil carrier sheet below the coils must not be closed.
- Components made from steel in the vicinity of the coils must not be magnetic.
- The Install-Line device must be easily accessible for installation and removal.
- The ceramic glass must be bonded using silicone that is compatible with foodstuff.
- The control switches must not be blocked.
- Keep flammable substances, vapors or liquids away from the induction unit.
- When installing, pay attention to the position of the connections. Otherwise, it may be that the cooking zones do not match the operation. (Connections always on the left side or in front).

## Ventilation Requirements



Read and understand all installation safety instructions regarding Clearance and Ventilation at the beginning of this chapter.

- Make sure that the induction device does not suck in hot ambient air or steam from another device, especially if the device is installed near heat-generating equipment such as fryers or ovens.
- See also installation example
- Optimal air circulation must not be impaired by the installation.
- The Compactmodules are to be equipped with a guided air supply. We recommend the use of the optionally available installation kit, which guarantees optimal air supply of the generator.
- The exhaust air must also be able to leave the stove.
- The maximum air flow of the fan is 120m<sup>3</sup>/h, so a minimum suction opening of 6500 mm<sup>2</sup> must be guaranteed.
- The exhaust air must not mix directly with the supply air
- The induction unit has an internal air cooling system. Prevent blocking the air duct (supply and exhaust air) with objects (fabric, wall, etc.).

## EXAMPLE VENTILATION WITH VENTILATION KIT

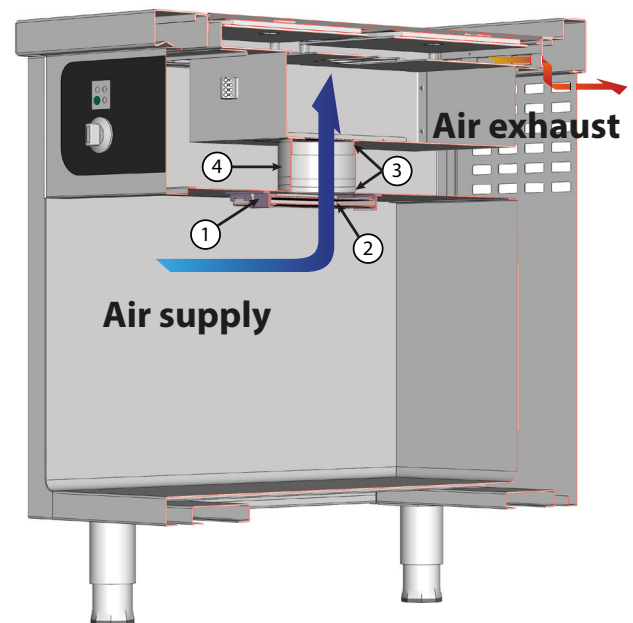

|   |                    |
|---|--------------------|
| 1 | Filter frame       |
| 2 | Filter             |
| 3 | Suction Connection |
| 4 | Fan tube           |

## COMMISSIONING



Read and understand all installation safety instructions regarding Electrical and Personal Protection.

1. Remove all objects from the glass-top and examine the glass.

### Caution

Do not continue if the glass-top is cracked, chipped or damaged in any other way. Contact an authorized service agency for assistance.

1. Connect the appliance to power supply.
2. Test different functions of the appliance.

## Function Test



- Read and understand all installation safety instructions regarding Personal Protection.
- Observe also ALL operation safety requirements in section 3 (Operation).

Testing procedure:

1. Examine the cookware for induction cooking:
  - Pans must be induction ready. See details in section 3 (Operation).
  - Minimum pan size: Pan must have bottom diameter larger than 12cm [5"]. Otherwise, the pan will not be heated. This is a safety feature. The sensors does not detect pan smaller than this minimum size.
3. Put some water in an induction pan and place it in the center of the cook-zone.
4. Follow operational instructions in section 3 to test:
  - Cook Mode with different power levels.
  - Hold Mode with set temperatures.<sup>1</sup>
  - Lock Function<sup>1</sup>
  - Timer Function<sup>1</sup>

5. Remove pan away from the cook-zone, the No Pan Icon is shown on display.<sup>1</sup>

6. Place the pan back on the cook-zone and the heating process resumes.<sup>1</sup>

NOTE: The LED ring illuminates continuously again when energy is being transferred to the pan.

7. Turn the appliance off. When the unit is switched off, a o appears on the display.<sup>1</sup>

If the appliance does not function as expected despite using quality induction pans, refer to section 5 (Troubleshooting).

To test the efficiency of a pan for induction cooking, refer to section 5 (Troubleshooting).

---

<sup>1</sup> This functions are only available with the Tap-Operation Single

## Section 3 Operation

### OPERATION SAFETY—DISCLAIMER

#### **⚠ DANGER**

The on-site supervisor is responsible to train operators for operating, maintaining and ensuring that operators are made aware of the inherent dangers of operating this equipment.

#### **⚠ DANGER**

Risk of fire/shock/equipment failure. **All minimum clearances must be maintained. Do not obstruct vents or openings.**

#### **⚠ Warning**

This equipment is intended for indoor use only. Do not install or operate this equipment in outdoor areas.

#### **Notice**

The reliability of the appliance can only be guaranteed when it is used properly. The appliance must always be operated within the limits and/or the operating conditions provided in this manual.

#### **Notice**

Avoid dropping any hard objects onto the equipment. Damages to the heating surface will shorten the life cycle of the equipment or incur high service costs.

#### **Notice – Models with Glass-Top**

##### **Use Only Induction Suitable Cookware**

Use only induction suitable cookware with proper sizes and made of proper material. The induction suitable cookware must be in good condition without any uneven, arched or partially detached bottoms.

Using unsuitable cookware can cause the appliance to fail prematurely, void your warranty, and incur high service costs.

**OPERATION SAFETY—PERSONAL PROTECTION**

**Notice**

Induction appliances are more powerful, heat up pans quicker, and cook food faster than conventional cooking equipment. Your induction appliance needs to be operated and looked after in a different way than other conventional equipment.

Do not operate the equipment without reading this manual and understanding all safety requirements.

**⚠ DANGER**

If any part of the appliance is cracked or broken, **turn off the appliance and immediately disconnect the appliance from supply.** Only if it is possible and safe, disconnect the equipment from main power supply. Do not touch any parts inside the appliance.

Disconnect electric power at the main power disconnecter for all equipment being serviced.

Failure to disconnect the power at the main power supply could result in serious injury or death. The knob DOES NOT disconnect incoming power.

Contact an authorized service agency for assistance.

**⚠ DANGER**

To avoid cardiac pacemaker malfunction, consult your physician or pacemaker manufacture about effects of electromagnetic field on your pacemaker.

**⚠ DANGER**

Never stand, sit, or lean on the equipment! They are not designed to hold the weight of an adult, and may collapse or tip if misused in this manner.

**⚠ Caution**

**Short Cook Time**

Induction appliances cook food faster than conventional cooking equipment. To avoid overheating and burning, check the cooking process frequently. Never leave the appliance unattended during operation.

**⚠ Caution**

Metallic objects are heated up very quickly when placed on the induction cook zone during operation. To avoid injury,

DO NOT place any objects such as closed cans, aluminum objects (aluminum foils), cutlery, jewelry, or watches on the appliance.

DO NOT place any object such as paper, cardboard, or cloth on the cooking surface, because this creates a fire hazard.

DO NOT place credit cards, phone cards, tapes, or any objects that are sensitive to magnetism on the appliance.

DO NOT use the appliance for storage.

DO NOT place any paper products, cooking utensils, cutlery, plastic vessels or food on the appliance.

DO NOT place metallic objects such as kitchen utensils, cutlery etc. on the hob surface within the cooking zones since they could get hot.

**⚠ Caution**

Aluminum foil must not be used with induction appliances! Aluminum foil may ignite and cause a fire!

**Notice**

Do not use the cooktop for food preparation such as cutting and chopping.



**⚠ Warning**

Risk of burns from high temperatures. You may get burnt if you touch any of the parts during operation. Surfaces close to the cooking area including side panels may get hot enough to burn skin. Use extreme caution to avoid coming in contact with hot surfaces or hot grease. Wear personal protective equipment.

**⚠ Warning**

Take care when operating the appliance, as rings, watches and similar objects worn by the user could get hot when in close proximity to the hob surface.

**⚠ Warning**

During operation, it is possible that the floor around the unit become slippery. Wear suitable footwear and clean the floor if necessary.

**Cooking with Induction Counter-Tops Models****⚠ Warning****Never Leave An Empty Pan On Cooktop**

Induction appliances heat up empty pans very quickly. Never operate the appliance with an empty pan. Do not pre-heat pan. Always put food products, water or oil into the pan before turning on the appliance. Failure to do so will result in irreparable damage.

**Notice****Broil-Dry Protection**

Cook zones are monitored by temperature sensors. The sensors can detect overheating at the base of a cooking pan.

When an overheated pan (overheated oil, empty pan) is detected, the appliance stops transferring energy to the pan immediately. You must turn off the appliance and let it cool down before re-starting the appliance.

**⚠ Caution****Do Not Touch Overheated Appliance**

To avoid burn injuries, do not touch the appliance when a pan is overheated and take all the necessary precautions when removing the overheated pan.

**⚠ Warning**

Steam can cause serious burns. Always wear some type of protective covering on your hands and arms when removing lids or pans from the appliance. Lift the lid or pan in a way that will direct escaping steam away from your face and body.

**⚠ Warning**

Never leave any pan during the cooking process unattended.

### Important Rules—Operation and Maintenance

Follow these simple rules to ensure reliable and repeatable performance of your induction equipment:

**1 Keep kitchen temperature below 40°C [104°F].**

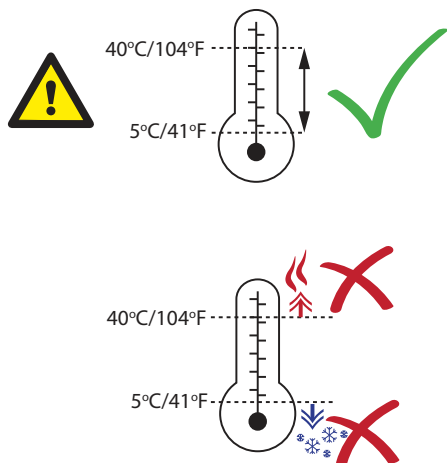

**4 Use only pans that fits the glass markings. Do not use oversized pans.**

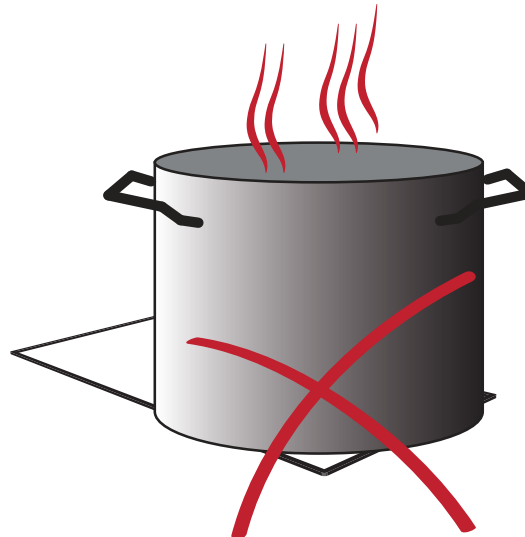

**2 Clean the intake filter at least once a week or as often as required.**



**5 Never pre-heat the pan. Place the pan on the only when you are ready to cook.**



**3 Do not use dented pans because it will cause damages to the electronics.**



### Proper Induction Cookware

#### CONDITION

- Pans with layer separation (outward and inward bubbles), arching or partially detached bottoms must be replaced.
- When these pans are used, the sensors under the glass-top cannot detect temperature correctly. These pans will overheat the sensors and eventually will damage the sensors and the generator. (Below, examples of good and bad pans in cross-sections.)

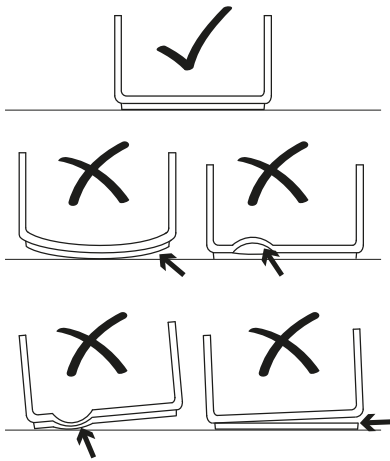

#### MATERIAL

- **USE** cookware made of **conductive and magnetic** materials. If the pan bottom attracts a magnet, the pan is suitable for induction cooking. Look for cookware that is labeled **suitable for induction** or with an induction compatible symbol.

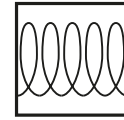

- **DO NOT USE** cookware made of aluminum, copper, glass or ceramics.
- NOTE—Steel inserts on bottom:

Cookware base inserted with areas of aluminum reduces the magnetic area for induction cooking. The appliance may supply less energy to the cookware or have difficulties in detecting the pan.

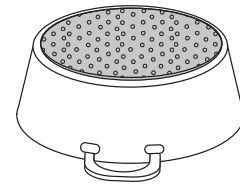

- NOTE—Non-magnetic cookware with a small magnetic base:

The exposed non-magnetic metal on the base may affect the induction field and subsequently, less energy may be supplied to the cookware.

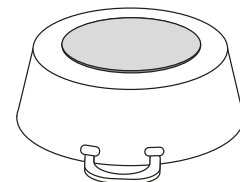

### BOIL TEST

To test the efficiency of a pan for induction cooking, perform a boil test. See instructions in section 5 Troubleshooting.

### SIZE OF PAN

- **MINIMUM SIZE:** The bottom of pan must have a minimum diameter of 12cm [5"] (below, dotted lines). Otherwise, the pan will not be heated. This is a safety feature such that the unit do not detect and heat up small metal objects, such as jewelry. NOTE: For personal safety, never place any small metallic objects on a cook zone.

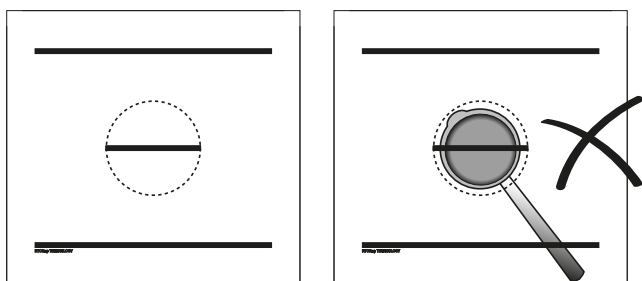

- **DO NOT USE OVERSIZED PAN!** The bottom of the pan must fit the glass. When a hot, oversized pan covers the silicone seal underneath, the heat from the pan may dry out the silicone overtime. When the silicone seal dries out and breaks, liquid can penetrate into the appliance and damage the electronics.

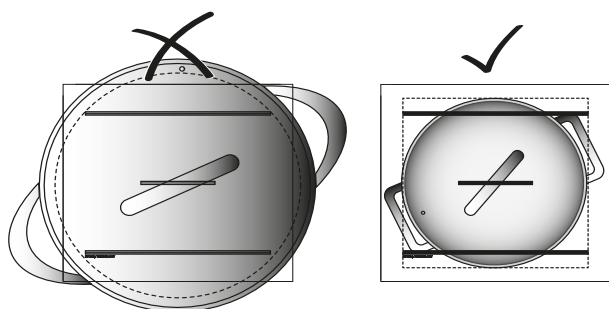

- **PAN MUST FIT THE GLASS!** The best pan to use is the one with a bottom that fits the coil (below, dotted lines).

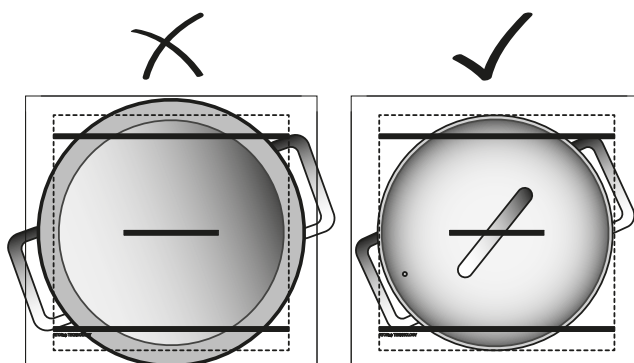

### Placing Pan On A Cooking Zone

Each cook zone of our appliances is equipped with the latest RTCSmp® sensors. These sensors monitor temperature and cookware continuously in real time.

To obtain optimal results from the sensors, you must **always place pan in the center of the cook zone**. Otherwise, the bottom of the pan is heated unequally and the food inside the pan may burn.

- **PLACE MAXIMUM ONE PAN PER COOKING ZONE ON A ROUND COIL.**

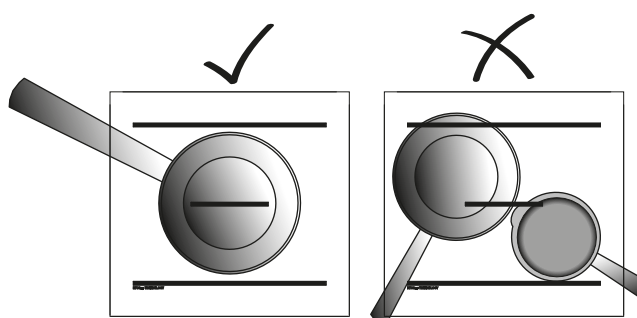

- **ALWAYS PLACE PAN IN THE CENTER OF A COOK ZONE.**

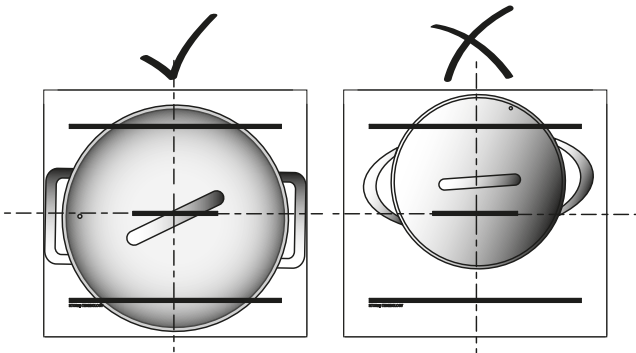

- **PAN MUST NOT COVER MORE THAN ONE COOK ZONE ON A DUAL/QUAD OR ON TWO SINGLE UNITS.**

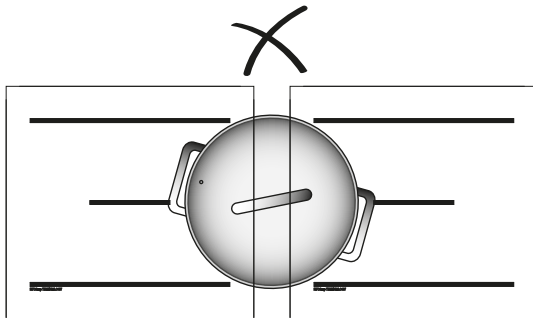

## Rotary power switch

The induction unit is turned on by turning the power rotary switch (OFF / ON). It is ready for immediate use. The glowing power indicator indicates that energy is transferred to the pan. The power level is set by turning the power selector (the bigger ridge indicates the Position):

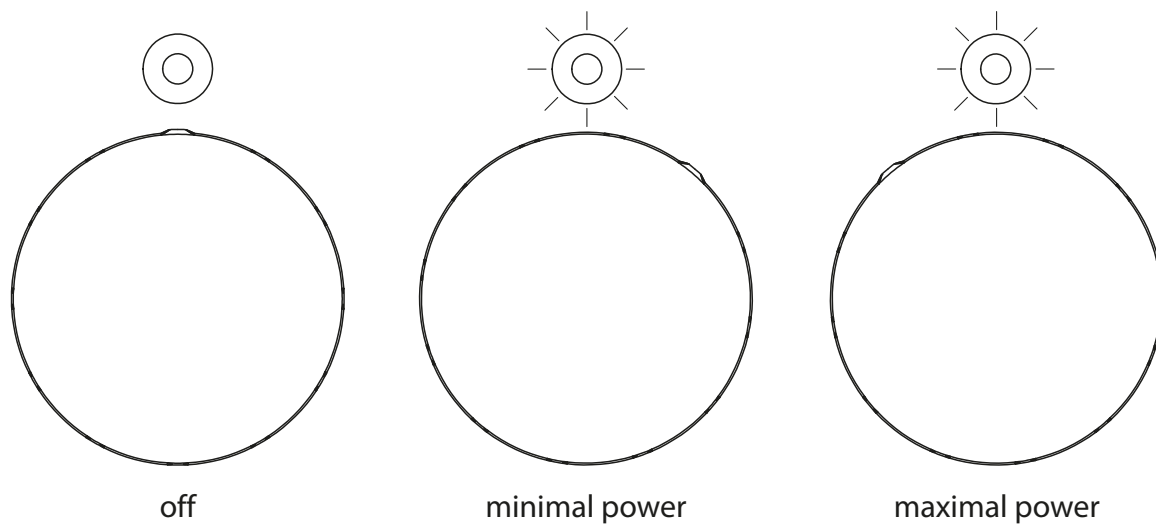

### Tap-Operation Display (Overview)

Note: Hold mode and Temperature function are not available for Wok Models

- Temperature, °C or °F**
- To set °C or °F, press down knob while connecting unit to power outlet.
  - Turn knob to select P2 option on display.
  - Click knob 1 time (1x) to confirm.
  - Turn knob to select °C or °F and click knob 1x to confirm.
  - To return to cook/hold mode, click and hold knob until other icons are shown on display.

- Timer, Minutes**
- After selecting temperature or power level, double click knob to switch to Timer Mode.
  - Turn knob to select time in minutes.
  - Click knob 1 time (1x) to confirm and start count-down.

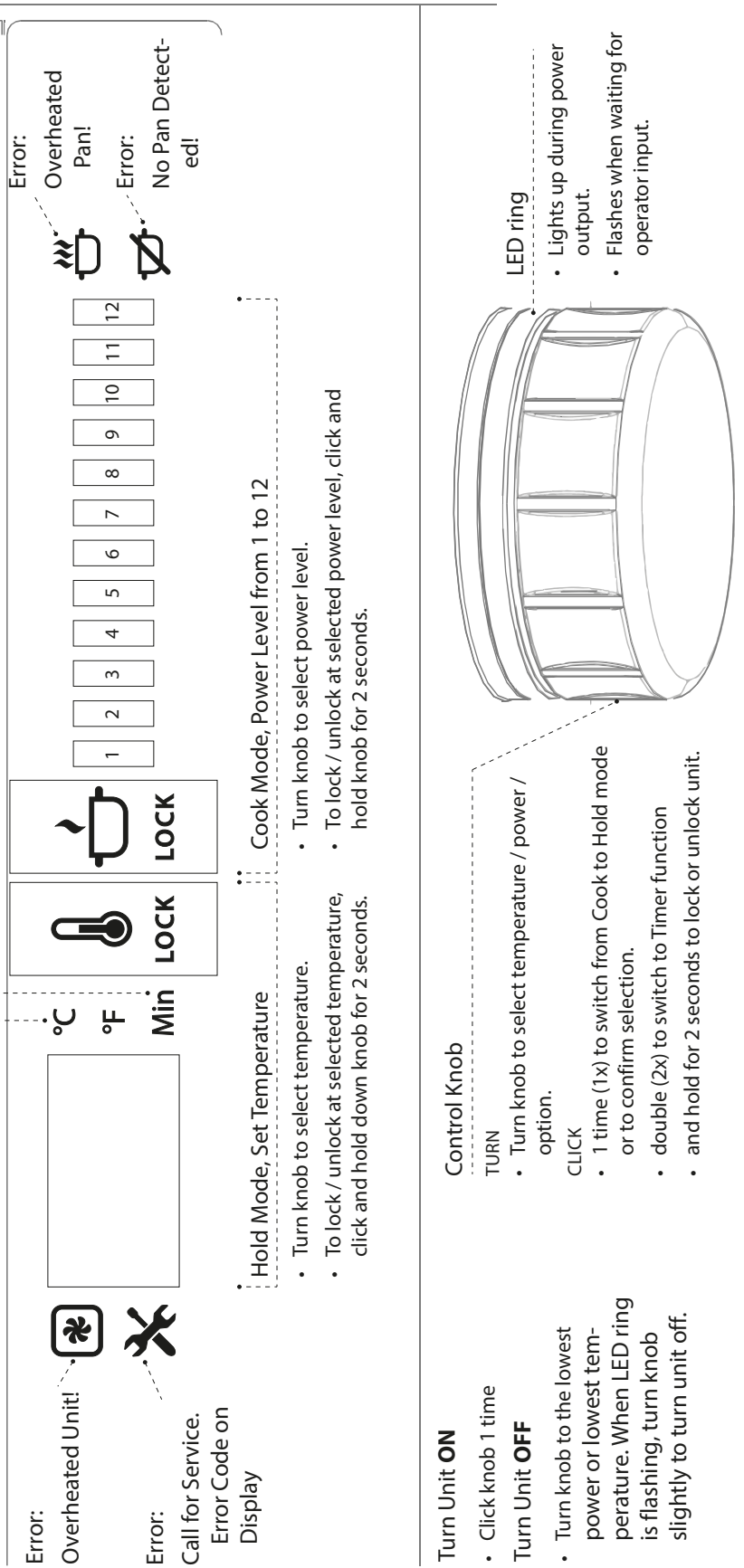

- Hold Mode, Set Temperature**
- Turn knob to select temperature.
  - To lock / unlock at selected temperature, click and hold down knob for 2 seconds.
- Cook Mode, Power Level from 1 to 12**
- Turn knob to select power level.
  - To lock / unlock at selected power level, click and hold knob for 2 seconds.

- Turn Unit ON**
- Click knob 1 time
- Turn Unit OFF**
- Turn knob to the lowest power or lowest temperature. When LED ring is flashing, turn knob slightly to turn unit off.
- Control Knob**
- TURN
- Turn knob to select temperature / power / option.
- CLICK
- 1 time (1x) to switch from Cook to Hold mode or to confirm selection.
  - double (2x) to switch to Timer function
  - and hold for 2 seconds to lock or unlock unit.

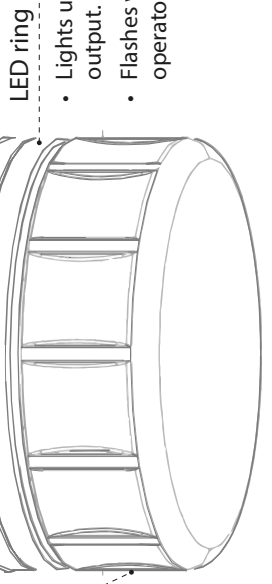

## Control

### TURN UNIT ON

Click knob and turn to select power level.

### LED RING

- The LED ring flashes if operator input is needed.
- The LED ring lights up continuously during cooking or holding.

### SWITCHING BETWEEN COOKING AND HOLDING MODES

Holding mode is not available for Compactmodul Wok.

1. During operation, click knob once. The LED flashes.
1. While watching the display, turn knob clockwise or counter-clockwise to activate Power Level Mode or Hold-Mode.
2. Click knob again to confirm selection.

### SETTING POWER LEVEL (1 TO 12) AND LOCK/UNLOCK

1. In Power Level Mode, turn knob clockwise to choose power level:
  - Power level (1) = lowest power
  - Power level (12) = highest power
3. To lock power at set level, press down knob until the word "LOCK" on the display lights up. This takes 2 seconds.
4. To unlock, press down knob again until the word "LOCK" on the display goes dark. This takes 2 seconds.

## Power Level Settings

The Power Diagrams (below) show that the difference in power output between two higher power levels is much larger than that between two lower power levels.

This power level and output relationship gives you a fine simmer-rate control in the low power range, and an instant response in the high power range.

### POWER DIAGRAM 1: POWER LEVEL 0 TO 12

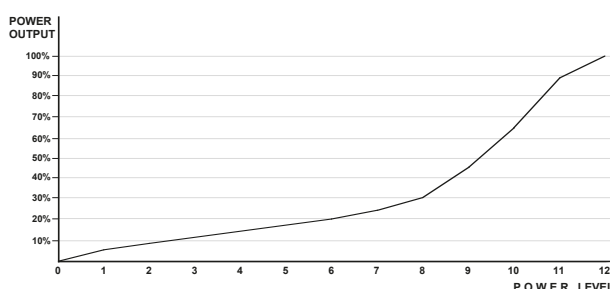

The settings from (1) to (9) span the lower 50% of the total Power Output; the settings from (10) to (12) cover the 50% to 100% output range.

### SELECTING HOLD TEMPERATURE AND LOCK/UNLOCK

1. In Hold-Mode, turn knob until the desired temperature is shown on the display.
5. Leave the knob for approximate 5 seconds, the display will show the actual detected temperature.
6. To lock temperature at set level, press down knob until the word "LOCK" on the display lights up. This takes 2 seconds.
7. To unlock, press down knob again until the word "LOCK" on the display goes dark. This takes 2 seconds.



## SETTING THE TIMER

The timer function can be set for both Cooking or Holding Modes.

1. After setting power level or temperature, double click the knob to switch to Timer Mode.
8. Turn knob to set the timer from minimum 1 minute to maximum 240 minutes. The LED ring will flash.
9. Click knob 1 time to confirm and start the count-down.
10. Note when using Hold-Mode with Timer, the display will show alternately the actual temperature and the count-down.
11. After the set time is elapsed, the appliance will sound a beeping signal and the unit will automatically shut down if the operator takes no action.

## TURNING UNIT OFF

When in Cook or Hold Mode, turn knob to go to the lowest power level or lowest temperature.

When LED ring is flashing, turn knob slightly to turn off the appliance.

When the unit is switched off, a  appears in the display.

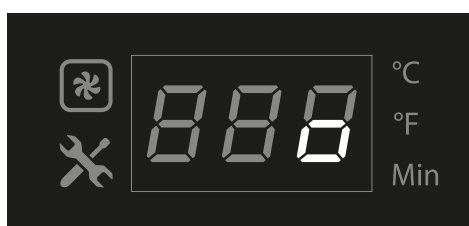

## Additional Settings

Additional settings are available to reduce power level, and to set display to °C or °F.

To activate the additional settings:

1. Press down knob while connecting unit to power outlet.
12. Then turn knob to select setting P1 or P2:
  - P1 = Reduce nominal max power from 100% to 25%
  - P2 = Change temperature from °C to °F (function not available on Wok models)
  - P3 = Shows the actual Firmware number.
  - P4 = Enable / Disable buzzer (timer function)
13. Click knob 1 time (1x) to confirm selection.
14. In P1, turn knob to select power. In P2, turn knob to select °C or °F. In P4, turn knob to select "on" or "off"
15. Click knob 1 time (1x) to confirm selection.
16. To leave the special setting function, keep pressing down the knob until the normal cooking or hold mode is shown on display.

## Automatic Pan Detection, No Pan No Heat

When a temperature or a power level is selected, the appliance supplies energy only when a pan is placed in the cook zone.

When you remove the pan from the cook zone, the appliance stops power output immediately. The power output resumes, when the pan is placed back on the cooking zone.

### Notice

Switch off the cook-top by means of the control. Do not rely on the Pan Detection as the ON-OFF control.

### Notice

Pan with a bottom diameter smaller than 12cm or 5" is not detected by the system.

## When the application is not in use

When the induction appliance is not in use, always turn off the appliance.

### Notice

Switch the appliance off if you take the cookware away for a while. This will prevent the heating process to start automatically and unintentionally when a pan is placed back on the heating area. If any person needs to use the induction appliance, he/she will have to turn the appliance ON intentionally.

## Decommissioning

Procedure if the device is not needed for a long time.

1. Switch off the device on the knob.  
(See Section 3 Turning Off)
17. Disconnect the device from the mains.

## Section 4 Maintenance

### MAINTENANCE SAFETY—DISCLAIMER

#### **DANGER**

It is the responsibility of the equipment owner to perform a Personal Protective Equipment Hazard Assessment to ensure adequate protection during maintenance procedures.

#### **Warning**

A good maintenance of the appliance requires regular cleaning, care and servicing. The site-supervisor and the operator must ensure all components relevant to safety are in perfect working order at all times.

NOTE: Cleaning tools and supplies are not provided.

### DANGEROUS ELECTRICAL VOLTAGE

#### **DANGER**

Do not open the appliance. Maintenance and servicing work other than cleaning as described in this manual must be done by an authorized service personnel.

#### **DANGER**

If any part of the appliance is cracked or broken, **turn off the appliance and immediately disconnect the appliance from supply.** Only if it is possible and safe, disconnect the equipment from main power supply. Do not touch any parts inside the appliance.

Disconnect electric power at the main power for all equipment being serviced.

Failure to disconnect the power at the main power supply could result in serious injury or death. The power switch DOES NOT disconnect all incoming power.

Contact an authorized service agency for assistance.

### MAINTENANCE SAFETY—CLEANING

#### **Warning**

Never use a high-pressure water jet for cleaning or hose down or flood interior or exterior of the equipment with water. Ensure that no liquid can enter into the equipment.

#### **Warning**

Allow heated equipment / glass surface to cool down before attempting to clean, service or move.

#### **Warning**

When cleaning the exterior, care should be taken to avoid front power switch and the electrical cords. Keep water and cleaning solutions away from these parts.

#### **Caution**

Do not use caustic cleaners on any part of the equipment. Use mild, non abrasive soaps or detergents, applied with a sponge or soft cloth.

#### **Caution**

Ensure to remove all residues of cleaning agents from the cooking surfaces. Use a clean moist cloth to wipe off any surfaces.

#### **Caution**

Using commercial cleaning fluids or chemicals: Read the directions for use and precautionary statements before use. Pay attention to the concentration of cleaner and the length of time the cleaner remains on the food-contact surfaces or equipment surfaces.

**Notice****Inspect and Clean Fresh Air Intake Filter**

We strongly recommend using air intake filters in all installations to protect the equipment from grease particles. A dirty, blocked air intake filter blocks the air vent and can cause damages to the electronic components. Inspect, clean or replace the air intake filters at least once a week or as often as necessary.

**⚠ Warning****Inspect Silicone Seal**

When the silicone seal is broken, water penetration could cause the appliance to fail, and any malfunction could cause personal harm.

**PERSONAL PROTECTION****⚠ DANGER**

All utilities (gas, electric, water and steam) must be OFF to all equipment and locked out of operation according to national/regional regulations, as well as company approved practices during installation, maintenance and servicing. Always allow appliance to cool.

**⚠ DANGER**

Use appropriate safety equipment during installation, maintenance and servicing.

**⚠ DANGER**

Never stand, sit, or lean on the equipment! They are not designed to hold the weight of an adult, and may collapse or tip if misused in this manner.

**⚠ DANGER**

To avoid cardiac pacemaker malfunction, consult your physician or pacemaker manufacture about effects of electromagnetic field on your pacemaker.

**⚠ DANGER**

Replace defective power cables immediately by an authorized service agency.

**⚠ Warning**

Markings and warning labels mounted directly on the equipment must be observed at all times and kept in a fully legible condition.

**⚠ Warning**

Risk of burns from high temperatures. You may get burnt if you touch any of the parts during operation. Surfaces close to the cooking area including side panels may get hot enough to burn skin. Use extreme caution to avoid coming in contact with hot surfaces or hot grease. Wear personal protective equipment.

**⚠ Warning**

During operation or cleaning, it is possible for the floor to become slippery around the unit. Wear suitable footwear and clean the floor when needed.

**⚠ Caution**

Use caution when handling the device. Metal edges can be sharp.

## Daily Cleaning and Maintenance

Clean the surface with a mild detergent and/or a food-safe liquid cleaner which not penetrate the silicone seal around the glass.

### GLASS CLEANING



**NOTE:** The cleaning of Ceran® glass is identical to cleaning other similar glass surfaces. You may use any regular glass cleaning products available from a hardware store.

You may use a razor blade scraper or a non-scratching sponge to remove tough residues. When scraping, place your razor blade scraper at an angle of about 20° to 30° from the glass. Then wipe clean the glass with a cleaning product.

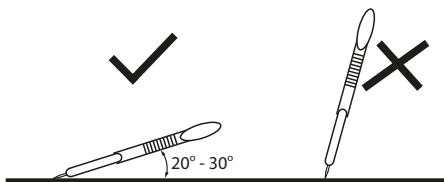

## VISUAL INSPECTION OF SILICONE SEAL

Inspect the silicone seal around the glass perimeter. Call for service immediately if you notice:

- Cracks on the silicone seal.
- The silicone seal comes away from the glass/housing or moves when you press down on the seal.

## Weekly Cleaning and Maintenance

If there is a Intake filter, clean and dry it.

## Yearly Maintenance

**Best Practice:** Have the induction appliance examined once a year by an authorized technician.

### General Maintenance Tips:

- Inspect all induction cookware to ensure proper condition.
- Have an authorized technician to inspect and ensure that:
  - All ventilation fans are working properly.
  - No grease built-up around the equipment and air filter.
  - The silicone joints of the ceramic and display glass are in good condition.

## Section 5 Troubleshooting

### DANGEROUS ELECTRICAL VOLTAGE

#### **⚠ DANGER**

If any part of the appliance is cracked or broken, **turn off directly the appliance and immediately disconnect the appliance from supply**. Only if it is possible and safe, disconnect the equipment from main power supply. Do not touch any parts inside the appliance.

Disconnect electric power at the main power for all equipment being serviced.

Failure to disconnect the power at the main power supply could result in serious injury or death.

The power switch DOES NOT disconnect all incoming power.

Contact an authorized service agency for assistance.

#### **⚠ DANGER**

Do not open the appliance. Maintenance and servicing work other than cleaning as described in this manual must be done by an authorized service personnel.

#### **⚠ Warning**

Markings and warning labels mounted directly on the equipment must be observed at all times and kept in a fully legible condition.

HINWEIS: If a problem arises during operation of your induction appliance, follow the Troubleshooting Charts before calling service. Routine adjustments and maintenance procedures are not covered by the warranty.

### Common Problems

One or more of the following conditions may affect the function or cause the induction equipment to fail:

- Using unsuitable cookware such as non-induction pans, oversized pans, or damaged pans.
- High ambient temperature.
- Inadequate ventilation causing hot air to re-enter through the air intake slots.
- Dirty air intake filter.
- Empty pan is left on the hob when the appliance is ON.

### Symptoms

- When a malfunction occurs, the appliance may be in one of the following states:
- The appliance switches off immediately.
- The appliance continues to operate in a power reduction mode.
- The appliance continues to operate normally.
- NOTE:

The cooling fan starts when the ambient temperature in the control area exceeds 55°C [130°F].

At heat sink temperature higher than 70°C [160°F], the controller automatically reduces power to keep the appliance in normal operating conditions.

## Boil Test

To test the quality of a pan for induction cooking, perform a boil test.

**This test is not applicable to griddles and braising pans. NEVER heat any cooking pan on a griddle plate or in a braising pan.**

(Test for 3.5kW or 5.0kW Induction Coil)

Perform a boil test to verify the performance of a pan for induction cooking.

- Add one liter of cold water into the pan (optimal when use pan with bottom diameter of 24cm) and bring it to boil. Compare the total boil time to the guideline below:
- 3.5kW Coil, approx. 140 seconds
- 5.0kW Coil, approx. 85 seconds

If time to boil exceeds the above guideline, then the pan is not suitable for achieving optimal efficiency. Please contact your supplier to purchase suitable induction pans.

If the induction appliance does not function as expected despite using quality induction pans, refer to the troubleshooting charts.

## Avoiding dangers in case of accidents or malfunctions

To avoid hazards in the event of a malfunction or accident related to the device, proceed as follows.

1. Disconnect the power supply from the circuit breaker provided for the device.
1. Disconnect the mains plug of the affected device to prevent it from being switched on again.

### DANGER

If the plug is not safely accessible, the device must be switched off at the main circuit breaker.

**Troubleshooting Without Error Code**

| <b>Symptom</b>   | <b>Possible Cause</b>  | <b>Action</b>   |
|--|--|---|
| Pan does not heat up on glass-top.<br>Digital display is OFF (dark).                         | No power supply.<br>Unit is turned off.<br>Defective unit.   | Check incoming power supply (Example, power cable plugged into the wall socket). Check kitchen main fuse box.<br>Turn control knob to an ON-position.<br>Only if possible and safe, disconnect the appliance from the power supply. Contact an authorized service agency. (1)   |
| Pan does not heat up and no pan symbol is on. (Not applicable to griddles or braising pans.) | Pan is too small.<br>Pan is not placed in the center of the hob; pan is not detected by sensor. (2)<br>Unsuitable pan.<br>Defective unit.  | Use a suitable pan with bottom diameter larger than 12cm [5"].<br>Move the pan to the center of the hob.<br><br>Select only induction-ready cookware.<br>Only if possible and safe, disconnect the appliance from the power supply. Contact an authorized service agency. (1)   |
| Poor heating, LED ring is ON   | Reduced Power adj.<br>Air-cooling system is obstructed.<br>Unsuitable pan.<br>Ambient temperature is too high.<br>The cooling system is not able to keep the appliance in normal operating conditions.<br>One phase is missing.<br>Defective unit. | Check Additional Setting "P1". See „Additional Settings“ on Page <?><br>Verify that air vents are not obstructed. Ensure the fresh air filter is clean.<br>Select various induction-ready cookware for induction cooking. Then compare the results.<br>Verify that no hot air is taken in by the fan. Reduce the ambient temperature. The intake air temperature must be lower than 40°C [104°F]. |
| Appliance does not react to control knob positions   | Unit is turned off.<br>Defective control knob.   | Check incoming power supply (Example, power cable plugged into the wall socket). Check kitchen main fuse box.<br>Only if possible and safe, disconnect the appliance from the power supply.<br>Contact an authorized service agency. (1)<br>Turn control knob to an ON-position.  |
| Overheated unit symbol is ON, fan is working   | Air-cooling system is obstructed.<br>Internal fan is dirty.  | Only if possible and safe, disconnect the appliance from the power supply. Contact an authorized service agency. (1)<br>Verify that air vents are not obstructed. Ensure the fresh air filter is clean.<br>Contact an authorized service agency.  |





| Symptom   | Possible Cause   | Action   |
|---|--|--|
| Overheated unit symbol is ON, fan does not work                     | Defective fan or fan control.  | Only if possible and safe, disconnect the appliance from the power supply. Contact an authorized service agency. (1) |
| Overheated unit symbol is ON  | Overheated induction coil; cooking area is too hot.<br>Overheated pan. Pan is empty. | Switch the appliance off. Safely remove pan. Wait until the appliance has cooled down before turning it ON.          |
| Small metallic objects (e.g. spoon) are heated up in the cook zone. | Pan detection function is defective.   | Only if possible and safe, disconnect the appliance from the power supply. Contact an authorized service agency. (1) |

- (1) **▲ DANGER** If the plug is not safely accessible, the device must be switched off at the main circuit breaker.
- (2) The appliance switches off immediately.

**Troubleshooting — Error Code**

| <b>Error Code (Display)</b>  | <b>Blink Code</b> | <b>Problem</b>   | <b>Action</b>  |
|--|-------------------|--|--|
| E01  | 1                 | Normal Operation.<br>Unsuitable induction cooking pan.<br>Internal wiring/coil connection malfunction. (2)   | Normal Operation.<br>Check pan material.<br>Contact an authorized service agency.  |
| E02  | 2                 | Unsuitable induction cooking pan.<br>Coil overcurrent. (2)   | Check pan material.<br>Contact an authorized service agency.   |
| E03 +       | 3                 | Air-cooling system obstructed. Fan malfunction.<br>Heat sink overheated. (2)   | Let appliance cool down.<br>Verify that air vents are not obstructed.<br>Check and clean air filter.<br>Contact an authorized service agency.  |
| E04 +       | 4                 | Overheated cook zone. Overheated pan detected. Sensor failure.   | Let appliance and/or pan cool down.<br>Check pan material.<br>Verify that air vents are not obstructed.<br>Check and clean air filter.<br>Contact an authorized service agency.  |
| E41, E42, E43, E44, E45, E46   | 4                 | Overheated or defective sensor. (2)<br>NOTE: Errors E41 to E46, griddles and braising pans may continue to operate.  | Contact an authorized service agency.  |
| E05  | 5                 | Potentiometer defective.   | Contact an authorized service agency.  |
| E06, E30 +  | 6                 | Ambient temperature too high (the cooling system is not able to keep the induction appliance in normal operating conditions). Internal component overheated. (2) | Contact an authorized service agency.<br>Let appliance cool down.<br>Verify that air vents are not obstructed.<br>Check and clean air filter.<br>Verify that no hot air is taken in by the fan. Reduce the ambient temperature. The intake air temperature must be lower than 40°C [104°F].<br>Contact an authorized service agency. |
| E07  | -                 | Phase failure.   | Check the fuses belonging to the socket to which the device is connected.<br>Contact an authorized service agency.   |
| E08  | -                 | Over- or undervoltage.   | Contact an authorized service agency.  |
| E10  | 10                | Communication problem of the CAN interface   | Contact an authorized service agency.  |
| E29  | 7                 | Generator component failure. (2)   | Contact an authorized service agency.  |

| Error Code (Display)  | Blink Code | Problem   | Action   |
|---|------------|---|--|
| E47   | 4          | Warning from overheated pan / cooking empty sensor or coil connection failed. (2)               | Let equipment / pan cool down.<br>Check pan material.<br>Check food in the pan or empty pan.                                     |
| E21 +  | 8          | Sensor error from heat sink. Ambient temperature beyond normal operating range. (2)             | Verify that air vents are not obstructed. Check air filter. Reduce ambient temperature.<br>Contact an authorized service agency. |
| E24 +  | 8          | Sensor error from CPU. Board overheated. Ambient temperature beyond normal operating range. (2) | Verify that air vents are not obstructed. Check air filter. Reduce ambient temperature.<br>Contact an authorized service agency. |

- (1) **▲ DANGER** If the plug is not safely accessible, the device must be switched off at the main circuit breaker.
- (2) The appliance switches off immediately.



**WELBILT®**  
*Bringing innovation to the table*

**WWW.WELBILT.COM**

Welbilt provides the world's top chefs, and premier chain operators or growing independents with industry leading equipment and solutions. Our cutting-edge designs and lean manufacturing tactics are powered by deep knowledge, operator insights, and culinary expertise.

All of our products are backed by KitchenCare® – our aftermarket, repair, and parts service.

- |               |               |              |           |              |              |
|---------------|---------------|--------------|-----------|--------------|--------------|
| ▶ CLEVELAND   | ▶ DELFIELD®   | ▶ FRYMASTER® | ▶ KOLPAK® | ▶ MANITOWOC® | ▶ MERRYCHEF® |
| ▶ CONVOTHERM® | ▶ FITKITCHEN™ | ▶ GARLAND    | ▶ LINCOLN | ▶ MERCOC®    | ▶ MULTIPLEX® |