

# Induction-Warming Plate

## Single Zones

---

### Operation And Installation Manual

**⚠ CAUTION:** Read the instruction before using the machine.

**⚠ WARNING:** If the surface is cracked, immediately disconnect the appliance from supply.

**Notice:** This Unit is approved for professional use only.

### Models

**Hold-Line 1-380**

**Hold-Line 1-GN**



This Manual can also be  
found as a PDF on  
[www.inducs.com](http://www.inducs.com)

Translation of Original Instruction – English

## READ THIS MANUAL

### **⚠ Warning**

Read this manual thoroughly before installing, operating, or performing maintenance on the equipment. Failure to follow instructions in this manual can cause property damage, injury or death.

This manual must always be available for reference at the place of operation.

This manual is intended for kitchen consultants, cabinet designers, fabricators, installers, owners and operators of our appliances.

Owners, consultants, fabricators and designers:

In order for the appliance to function safely and normally, you must read and understand all specific and critical requirements (such as location, ventilation, clearance) when designing the location and/or the electrical cabinet for the appliance.

Installers, operators and staff:

For your safety and safety of the others, you must follow all safety instructions during installation, operation and maintenance of the equipment.

Should you require technical assistance, call your authorized service agent or distributor.

**Always have model and serial number available when you call.**

Your Authorized Service Company and Contact Information

Your Equipment Supplier and Contact Information

Model Number

Serial Number

Date of Installation

## **ABOUT THIS MANUAL**

Throughout this manual, the induction appliance model indicated on the cover page is referred to as **appliance, induction appliance** or **equipment**.

A period (.) is used in this manual as the decimal separator.

Original measurements are in metrics. Measurements in imperial are provided for reference.

Not ALL models, options and accessories are available in all geographical regions. Please consult your equipment supplier for the availability of the specific products in your region.

## **INSPECT THE SHIPMENT**

Thoroughly inspect the equipment upon delivery. Immediately report to the delivery carrier, any damage that occurred during transportation and request for a written inspection report from a claim adjustor.

Keep all packaging.

## **KEEP THE DELIVERY NOTE**

The packing slip attached to the shipment contains detailed information on all components. Keep the delivery note for reference.

## Safety Notices

### DEFINITIONS

#### **DANGER**

Indicates a hazardous situation that, if not avoided, will result in death or serious injury. This applies to the most extreme situations.

#### **Warning**

Indicates a hazardous situation that, if not avoided, could result in death or serious injury.

#### **Caution**

Indicates a hazardous situation that, if not avoided, could result in minor or moderate injury.









#### **Notice**

Indicates information considered important, and is used to address practices not related to physical injury. For example, messages relating to property damage.

Note: Indicates useful, extra information about the action you are performing.

Reference: ANSI Z535.6-2011

### SAFETY SYMBOLS AND WARNINGS ON THE APPLIANCE

	This symbol alerts you to a hazardous situation that WILL or COULD cause serious bodily harm or death. Be alert and implement relevant safety precautions.
	<b>DANGER - HIGH VOLTAGE</b> This dangerous voltage warning symbol indicates a risk of electric shock and hazards from dangerous voltage.
	<b>Electromagnetic Field</b> This symbol warns against non-ionizing electromagnetic radiation.
	<b>Equipotential bonding</b> This symbol marks the terminal which has to be connected with the equipotential bonding system.
<div style="text-align: center;">  Warning   <b>RISK OF FIRE OR ELECTRIC SHOCK! DO NOT OPEN!</b>                      To reduce the risk of fire or electric shock, do not remove or open cover.                      Refer servicing to qualified personnel.                 </div>	
<div style="text-align: center;">  <b>DANGER</b>                      Disconnect from supply circuit before opening.                 </div>	
<div style="text-align: center;"> <b>CAUTION  ATTENTION</b>                      DISCONNECT FROM SUPPLY CIRCUIT BEFORE OPENING                      COUPER L'ALIMENTATION ELECTRIQUE AVANT D'OUVRIR                      DESCONNECTAR DEL CIRCUITO DE SUMINISTRO ANTES DE ABRIR                      Αποσυνδέστε από τον καλωδιακό εξοπλισμό πριν ανοίξετε                      إ فصل الجهاز عن الدائرة الكهربائية قبل الفتح.                 </div>	

**DISCLAIMERS****⚠ DANGER**

Disregarding any safety instructions may cause harm to people, the surroundings, and the equipment. The manufacturer and/or authorized representative are not responsible for any damages or personal injury caused by failure to observe any safety instructions. Risks involved when disregarding safety instructions include, but not limiting to:

- Death or injury caused by electric shock.
- Burn injury caused by contacting hot cooking surface, cookware, or oil and grease.
- Damage to the equipment caused by using unsuitable cookware.

**⚠ DANGER**

Do not install or operate equipment and/or accessories that have been misused, abused, neglected, damaged, or altered from that of original manufactured specifications.

**⚠ DANGER**

Contact the manufacturer if you intend to make any changes on the equipment. For safety reasons, always use genuine parts and accessories approved by the manufacturer or authorized representative. Refer to the warranty documents for your equipment.

**⚠ DANGER**

Owners and operators are cautioned that maintenance and repairs must be performed by an authorized service agent using only genuine replacement parts. The manufacturer will have no obligation with respect to any product that has been improperly installed, adjusted, operated or not maintained in accordance with national and local codes and/or installation instructions provided with the product or any product that has its serial number defaced, obliterated or removed, and/or which has been modified or repaired using unauthorized parts or by unauthorized service agents.

**⚠ DANGER**

Improper installation, adjustment, alteration, service, or maintenance of this appliance or installation of a damaged appliance can result in DEATH, INJURY, EQUIPMENT DAMAGE, and void the warranty.

**⚠ DANGER**

All power connections and fixtures must be maintained in accordance with local and national codes.

**⚠ Warning**

Do not store or use gasoline or other flammable vapors or liquids in the vicinity of this or any other appliance. Never use flammable oil soaked cloths or combustible cleaning solutions for cleaning.

**⚠ Warning**

This appliance is not intended for use by persons (including children) with reduced physical, sensory or mental capabilities, or lack of experience and knowledge, unless they have been given supervision concerning use of the appliance by a person responsible for their safety. Do not allow children to play with this appliance.

**⚠ Warning**

This product contains chemical known to the State of California to cause cancer and/or birth defects or other reproductive harm. Operation, installation, and servicing of this product could expose you to airborne particles of glass-wool or ceramic fibers, crystalline silica, and/or carbon monoxide. Inhalation of airborne particles of glass-wool or ceramic fibers is known to the State of California to cause cancer. Inhalation of carbon monoxide is known to the State of California to cause birth defects or other reproductive harm.

**⚠ Warning**

Authorized Service Representatives are obligated to follow industry standard safety procedures, including, but not limited to, local/national regulations for disconnection / lock out / tag out procedures for all utilities including electric, gas, water and steam.

**Notice**

This appliance is not approved or authorized for home or residential use, but is intended for commercial applications only. The manufacturer and/or authorized representative will not provide service, warranty, maintenance or support of any kind other than in commercial applications.

**Notice**

Routine adjustments and maintenance procedures outlined in this manual are not covered by the warranty.

Note: Proper installation, care and maintenance are essential for maximum performance and trouble-free operation of your equipment. Visit our website for manual updates, translations, or contact information for service agents in your area.

**CORRECT DISPOSAL OF THIS PRODUCT**



This marking shown on the product indicates that the product should not be disposed as household waste or regular commercial waste. Instead it shall be

handed over to the applicable collection point for the recycling of electrical and electronic equipment. By ensuring this product is disposed correctly, you will help prevent potential harm to the environment or human health, which could otherwise be caused by inappropriate waste handling of this product.

For more detailed information regarding recycling of the product, please contact your local city office or your waste disposal service.

Note: The appliance is built with common electrical, electromechanical and electronic parts. No batteries are used.

Note: The owner and operator are responsible for the proper and safe disposal of the appliance.

**Important**

**Additional Safety Notices are stated in the relevant sections throughout the manual.**



# Table of Contents

---

## Safety Notices

Definitions .....	4
Safety symbols and Warnings on the Appliance .....	4
Disclaimers .....	5
Correct Disposal of this Product .....	6

## Table of Contents

### Section 1

#### General Information

<b>Description of Product .....</b>	<b>10</b>
<b>Application .....</b>	<b>10</b>
<b>Compliances .....</b>	<b>10</b>
<b>Serial Plate Location .....</b>	<b>10</b>
<b>Model number and serial number .....</b>	<b>11</b>
<b>Serial Number .....</b>	<b>11</b>
<b>Ordering Information .....</b>	<b>11</b>

### Section 2

#### Installation

Installation Safety—Disclaimer .....	12
Installation Safety—Clearance and Ventilation .....	12
Installation Safety—Electrical .....	13
Personal Protection .....	14
<b>Specifications .....</b>	<b>15</b>
Dimensions: Hold-Line 380 .....	15
Dimensions: Hold-Line GN .....	16
Dimensions: Touch Operating Unit .....	17
Electrical Specifications .....	18
Electrical Cables .....	18
Operating Conditions .....	18
Weights .....	18
<b>Installation Guide .....</b>	<b>19</b>
Location of the Induction Appliance .....	19
Installation suggestion for an optimal air circulation .....	19
Commissioning .....	20
<b>Function Test .....</b>	<b>20</b>



**Section 3  
Operation**

Operation Safety—Disclaimer .....21  
 Operation Safety—Personal Protection .....22  
**Important Rules—Operation and Maintenance .....25**  
**Proper Induction Cookware .....26**  
 Condition .....26  
 Material.....26  
 Size of Pan.....27  
**Placing Pan On A Cook Zone .....28**  
**Short overview Display and Operation.....29**  
**Control .....30**  
 Turn unit on.....30  
 Display .....30  
 Selection of holding temperature and lock / unlock Function .....30  
 Turn Unit off.....30  
**Automatic Pan Detection .....31**  
**When Appliance Is not in use .....31**  
**Decommissioning .....31**

**Section 4  
Maintenance**

Maintenance Safety—Disclaimer.....32  
 Dangerous Electrical Voltage.....32  
 Maintenance Safety—Cleaning.....32  
 Personal Protection.....33  
**Daily Cleaning and Maintenance.....34**  
 Glass Cleaning.....34  
 Visual Inspection of Silicone Seal .....34  
**Yearly Maintenance .....34**

**Section 5  
Troubleshooting**

Dangerous Electrical Voltage.....35  
**Common Problems .....35**  
**Symptoms.....35**  
**Avoiding Danger in case of accidents or malfunctions .....36**  
**Troubleshooting Without Error Code .....37**  
**Troubleshooting — Error Code.....38**

# Section 1

## General Information

---

### Description of Product

Built with a robust construction, our induction appliances are compact and powerful with the revolutionary RTCSmp® Technology (Real-time Temperature Control System).

The RTCSmp® Technology monitors continuously in real-time, the energy supply, temperature of the cook zone and the state of the components such as the induction coil. This monitoring system ensures the most efficient energy transfer, as well as maximizes safety:

- Safety functions such as Pan Detection and Boil Dry Protection are therefore guaranteed.
- The appliance starts heating only when a pan is placed in the cook zone.
- When a malfunction occurs, the integrated fault diagnostic system reports the malfunction instantly.

### Application

The Compactmodul induction units are designed as compact units for installation in a closed stove or counter with openings for ventilation (see Section 2).

This device allows you a flexible use because:

- The temperature control is precise.
- The temperature can be adjusted quickly.

NOTE: To ensure device reliability and performance, you must use the recommended container pot or pan types and sizes with the device. See section 3 Operation.

### Compliances



**CE models** comply with the latest European Norms:

- EN 55014-1
- EN 55014-2
- EN 60529
- EN 62233 (EMC/EMV)
- EN 60335-1
- EN 60335-2-36
- EN 61000-3-11
- EN 61000-3-12

### Serial Plate Location

The serial plate is located on the bottom panel of the unit. It specifies the model number, serial number, and electrical specifications of the appliance.

## Model number and serial number

The model and serial numbers are located on the serial plate. This manual applies only to the models listed on the front of this manual.

### READING THE MODEL NUMBER

[Model Name] [Power]-[Size]-[plug type]

Model name	Power	Size	Plug Type
Hold-Line	1 = 1kW	380 = Holding device with the dimensions 380mm x 380mm [14.96" x 14.96"] GN = Warming rack for GN trays	EU = F (Schuko) CH = J (Switzerland, Type 23) UK = G NA = NEMA6/20

## Serial Number

Serial number is located on the serial plate.

## Ordering Information

Available models	Power	Size	Plug type <sup>1</sup>	Voltage
Hold-Line 1-380-EU	1kW	380mm x 380mm [14.96" x 14.96"]	F (Schuko)	208 - 240V
Hold-Line 1-380-CH	1kW	380mm x 380mm [14.96" x 14.96"]	J (CH, 16A)	208 - 240V
Hold-Line 1-380-UK	1kW	380mm x 380mm [14.96" x 14.96"]	G (UK)	208 - 240V
Hold-Line 1-380-NA	1kW	380mm x 380mm [14.96" x 14.96"]	NEMA6/20	208 - 240V
Hold-Line 1-GN-EU	1kW	520mm x 320mm [20.47"x12.6"]	F (Schuko)	208 - 240V
Hold-Line 1-GN-CH	1kW	520mm x 320mm [20.47"x12.6"]	J (CH, 16A)	208 - 240V
Hold-Line 1-GN-UK	1kW	520mm x 320mm [20.47"x12.6"]	G (UK)	208 - 240V
Hold-Line 1-GN-NA	1kW	520mm x 320mm [20.47"x12.6"]	NEMA6/20	208 - 240V

<sup>1</sup> The electrical specifications with the connector types can be found on page18

## Section 2 Installation

### INSTALLATION SAFETY—DISCLAIMER

#### **⚠ DANGER**

Installation must be carried out by registered installation contractors only.

The contractors are responsible for interpreting all instructions correctly and performing the installation in compliance with all applicable national and local regulations.

The warning signs and serial plates on the equipment must strictly be followed.

#### **⚠ Warning**

This equipment is intended for indoor use only. Do not install or operate this equipment in outdoor areas.

#### **⚠ Warning**

To avoid instability, the installation area must be capable of supporting the combined weight of the equipment and food product. The equipment must be level side to side and front to back.

#### **⚠ Caution**

Consultants, fabricators and designers must consult their counter-top suppliers when designing an appropriate support structure and clearance for the installation.

#### **Notice**

The glass must be glued in with a food-grade and heat-resistant silicone.

#### **Notice**

Induction equipment that is not installed correctly will have warranty voided.

### INSTALLATION SAFETY—CLEARANCE AND VENTILATION

#### **⚠ DANGER**

#### **Risk of Fire or Shock or Equipment Failure**

All minimum clearances must be maintained. Air intake vents and exhaust vents must not be blocked or be restricted by the installation.

#### **Notice**

**The maximum ambient temperature for the induction appliance to operate must not exceed 40°C [104°F].**

**Failure to provide adequate ventilation will cause the appliance to overheat, to reduce power, or to shutdown.**

#### **Notice**

The induction unit must not be installed above an oven or any other source of heat in the substructure.

Note: Always maintain enough space between and around the equipment for maintenance and service.

**INSTALLATION SAFETY—ELECTRICAL****⚠ DANGER**

All electrical connections must be carried out by a certified electrical contractor, who is responsible for the correct rating and installation of the appliance. The contractor has to comply with all legal safety regulations and all applicable national and local electrical codes.

**⚠ Warning**

Markings and warning labels mounted directly on the equipment must be observed at all times and kept in a fully legible condition.

**⚠ Warning**

This equipment must be positioned so that the plug is accessible unless other means for disconnection from the power supply, such as circuit breaker or disconnect switch, is provided.

**⚠ Warning**

**CE Induction Appliance only:** If ground fault current protective switches are used, they must be designed for a minimum fault current of 30mA, Type B or B+.

**Notice**

Ensure the supply voltage and the line current match the specifications given on the serial plate affixed to the appliance. Wrong voltage will damage the appliance. A stable power supply must be provided.

**Notice**

Always refer to the serial plate on the appliance to verify the electrical data. When the data listed on the serial plate is different than that listed in this manual, contact the manufacturer or the authorized representative.

**Notice**

All cables must be routed, protected and tension free.

**PERSONAL PROTECTION****⚠ DANGER**

All utilities (gas, electric, water and steam) must be OFF to all equipment and locked out of operation according to national/regional regulation, as well as company approved practices during installation, maintenance and servicing. Always allow appliance to cool.

**⚠ DANGER**

Use appropriate safety equipment during installation, maintenance and servicing.

**⚠ DANGER**

Never stand, sit, or lean on the equipment! They are not designed to hold the weight of an adult, and may collapse or tip if misused in this manner.

**⚠ DANGER**

To avoid cardiac pacemaker malfunction, consult your physician or pacemaker manufacture about effects of electromagnetic field on your pacemaker.

**⚠ DANGER**

Replace defective power cables immediately by an authorized service agency.

**⚠ Warning**

Markings and warning labels mounted directly on the equipment must be observed at all times and kept in a fully legible condition.

**⚠ Warning**

Risk of burns from high temperatures. You may get burnt if you touch any of the parts during operation. Surfaces close to the cooking area including side panels may get hot enough to burn skin. Use extreme caution to avoid coming in contact with hot surfaces or hot grease. Wear personal protective equipment.

**⚠ Caution**

Use caution when handling device. Metal edges of all equipment can be sharp.

## Specifications

### DIMENSIONS: HOLD-LINE 380

Dimensions are specified in mm [inches].

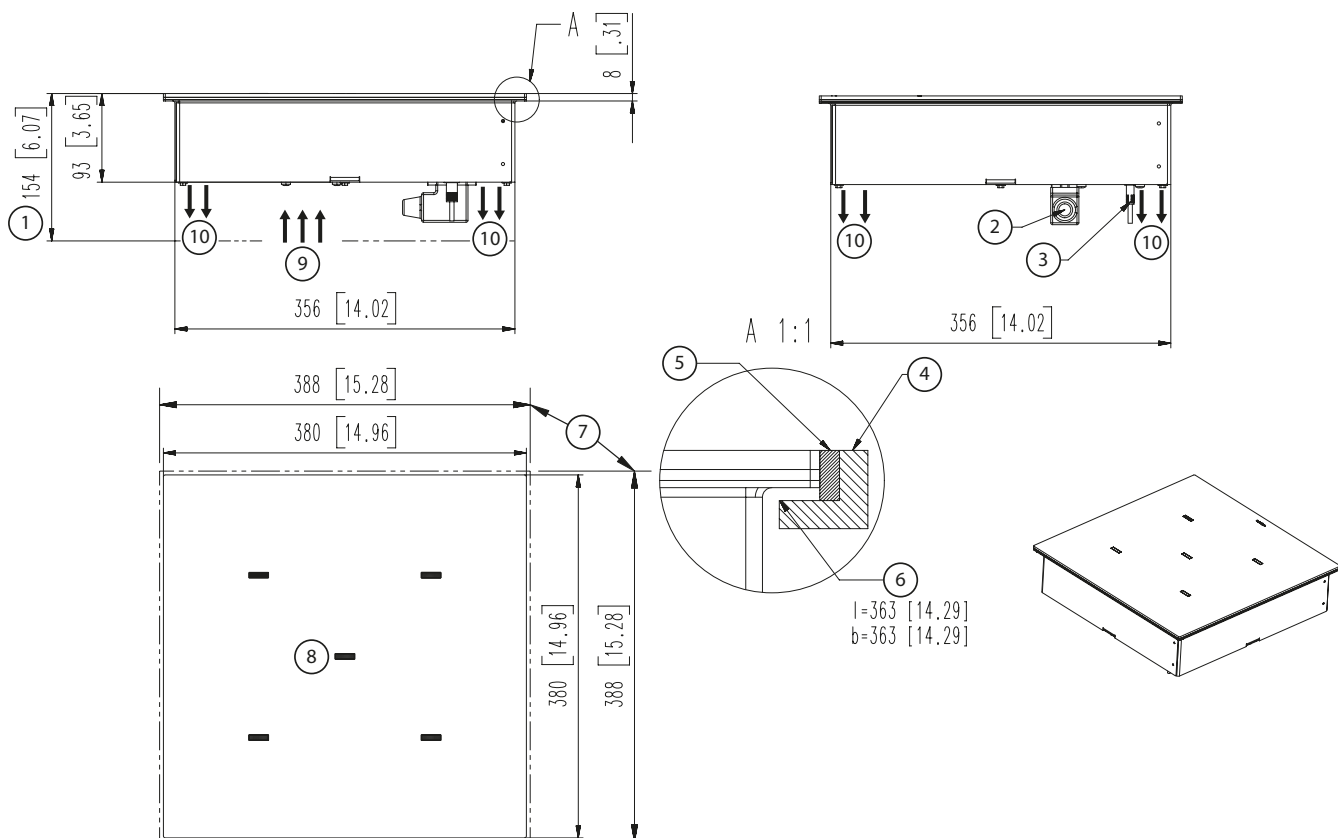

1	Minimal mounting height
2	Power Cable Connection
3	RJ-45 Plug-In for operating device
4	Counter top
5	Silicone joint
6	Counter cut out
7	Cut out on the work surface
8	Position of the temperature sensors 
9	Air supply
10	Air exhaust
→	Indicates the direction of airflow

**DIMENSIONS: HOLD-LINE GN**

Dimensions are specified in mm [inches].

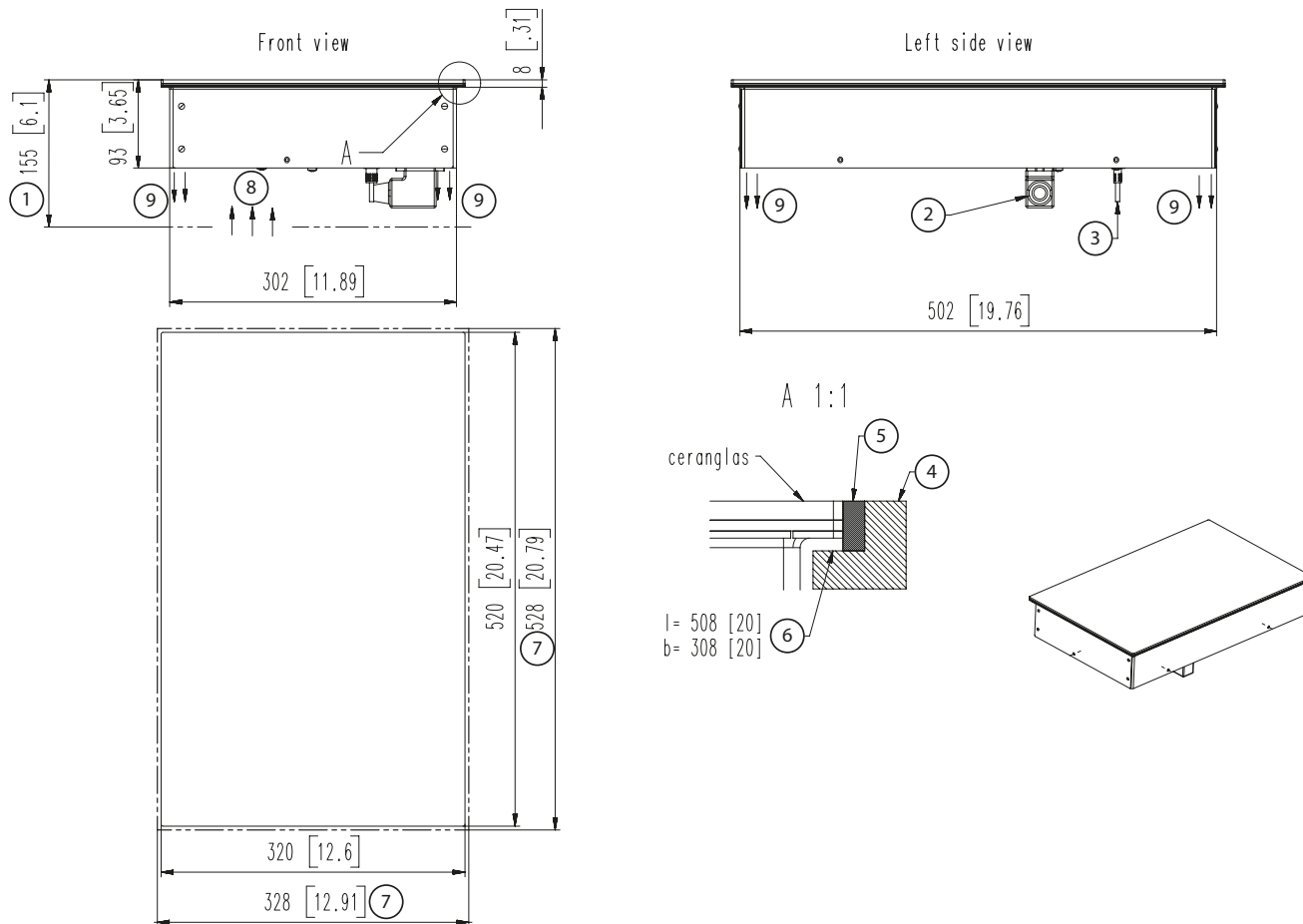

➔	Indicates the direction of airflow
1	Minimal mounting hight
2	Power Cable Connection
3	RJ-45 Plug-In for operating device
4	Counter top
5	Silicone joint
6	Counter cut out
7	Cut out of the work top
8	Air supply
9	Air exhaust









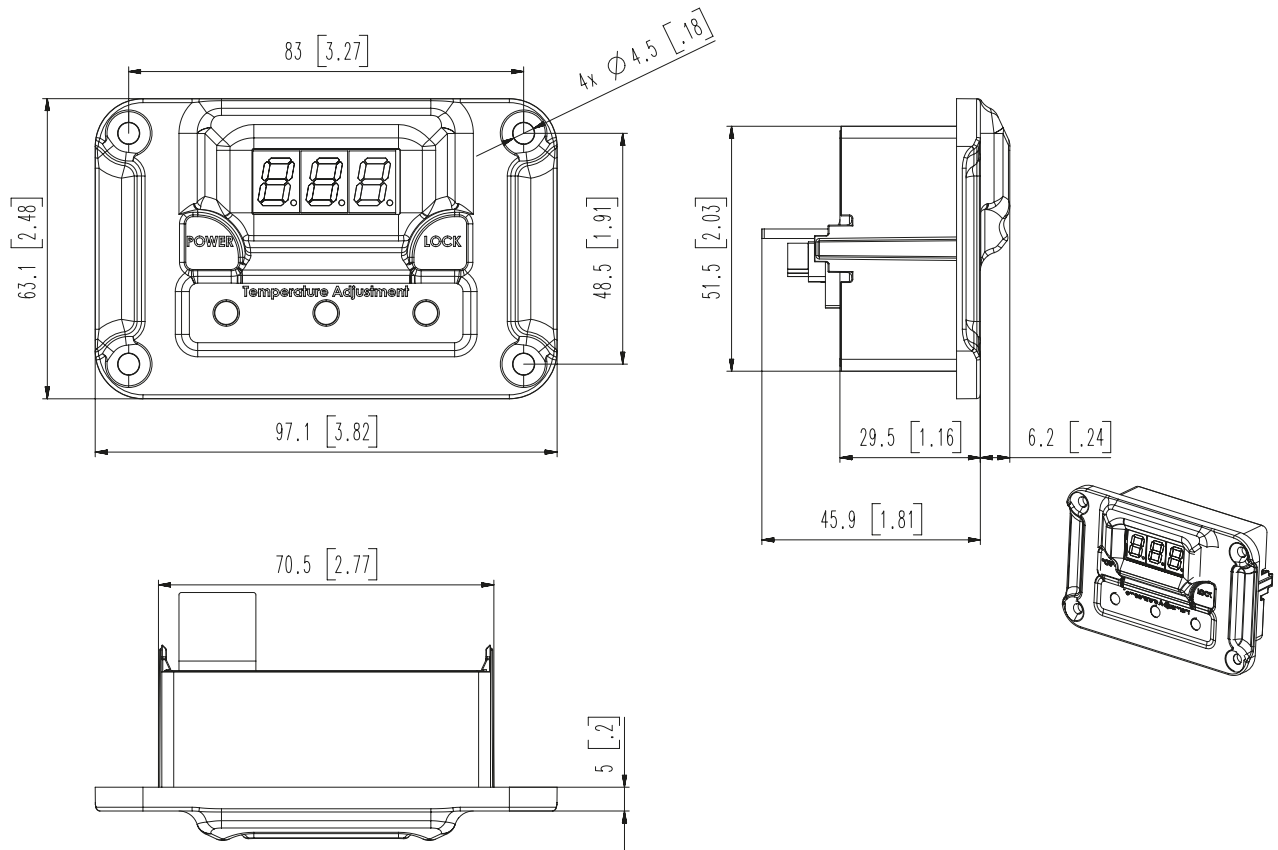

### DIMENSIONS: TOUCH OPERATING UNIT

Dimensions are specified in mm [inches].

Cut-out size : 72mm [2.83"] x 53mm [2.08"]



**ELECTRICAL SPECIFICATIONS**

Model	Power / Current	Voltage / Phases	Plug
Hold-Line 1-380	1000W / 4.5A	230V / 1Φ	 CH-TYP 23
			 TYP G
			 EU1-16P
	1000W / 4.9A	208V / 1Φ 208V / 2Φ	 NEMA 6-20P
Hold-Line 1-GN	1000W / 4.5A	230V / 1Φ	 CH-TYP 23
			 TYP G
			 EU1-16P
	1000W / 4.9A	208V / 1Φ 208V / 2Φ	 NEMA 6-20P

**OPERATING CONDITIONS**

For the appliance to function properly, the following conditions must be maintained.

Maximum Tolerance of the Nominal Supply Voltage	+6 /-10 %
Supply frequency	50/60 Hz
Minimal Diameter of Induction Pan	12 cm [5"]
Maximum Ambient Temperature	Storage: -20°C to +70°C [-4°F to +158°F]
	Operation: +5°C to +40°C [+41°F to +104°F]
Maximum Relative Air Humidity	Storage: 10% to 90%
	Operation: 30% to 90%

**WEIGHTS**

Model	Net Weight	
	kg	lb
Hold-Line 1-380	7.5	16.6
Hold-Line 1-GN	8.5	18.8

**ELECTRICAL CABLES**

Power supply cable and plug are included, 1.8-meter [6-foot] long.

## Installation Guide

### LOCATION OF THE INDUCTION APPLIANCE

**⚠ Caution**

Make sure that the air inlet is not near the steam or heat vent of another device. The openings for air inlet and outlet must not be blocked, as this leads to heat build-up inside the unit.

- The distance from device to device is min. 10cm [4,,]
- The induction unit must not be installed near a hot surface or in a hot surface.
- The air intake temperature must be below 40 °C [104 ° F]. Make sure that the escaping air is not sucked directly into the unit.
- Like other electronic devices, induction devices are sensitive to moisture and high heat. Protect the induction unit from heat, steam and grease caused by other appliances such as the oven, fryer, pasta cooker, steamer and water bath.
- The operation must not be blocked.
- Keep the induction unit away from flammable substances, vapors or liquids.

### INSTALLATION SUGGESTION FOR AN OPTIMAL AIR CIRCULATION

Cut away view:

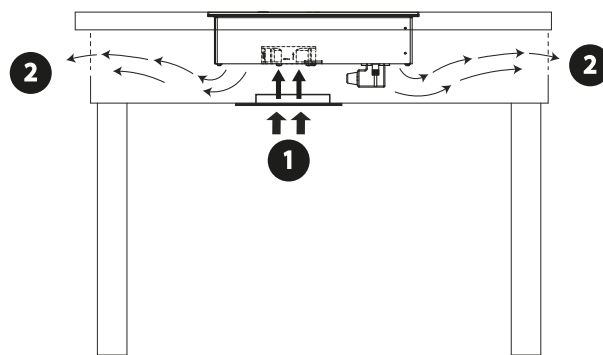

1	Air supply
2	Air exhaust

## COMMISSIONING



Read and understand all installation safety instructions regarding Electrical and Personal Protection.

1. Remove all objects from the glass-top and examine the glass.

### Caution

Do not continue if the glass-top is cracked, chipped or damaged in any other way. Contact an authorized service agency for assistance.

2. Connect the appliance to power supply.
3. Test different functions of the appliance.

## Function Test



- Read and understand all installation safety instructions regarding Personal Protection.
- Observe also ALL operation safety requirements in section 3 (Operation).

Testing procedure:

1. Use a pan or container suitable for induction to keep food warm:
  - Pans must be induction ready. See details in section 3 (Operation).
  - Minimum pan size: Pan must have bottom diameter larger than 12cm [5"]. Otherwise, the pan will not be heated. This is a safety feature. The device does not detect pan smaller than this minimum size.
  - The devices marked as GN may only be operated with suitable GN containers (1/1, 1/2, 1/3, 2/4 GN).
2. Put some water in the cookware or the warming utensils and place them in the middle of the cooking zone.
3. Set the holding temperature to 65°C [149°F]
4. Take the pan off the cooking zone; Now the display shows the „no pan“ symbol.



5. Put the pan back on the cooking zone and the heating process will continue.
6. Turn the appliance off. When the unit is switched off, a  appears on the display.

If the appliance does not function as expected despite using quality induction pans, refer to section 5 (Troubleshooting).

To test the efficiency of a pan for induction cooking, refer to section 5 (Troubleshooting).

## Section 3 Operation

### OPERATION SAFETY—DISCLAIMER

#### **⚠ DANGER**

The on-site supervisor is responsible to train operators for operating, maintaining and ensuring that operators are made aware of the inherent dangers of operating this equipment.

#### **⚠ DANGER**

Risk of fire/shock/equipment failure. **All minimum clearances must be maintained. Do not obstruct vents or openings.**

#### **⚠ Warning**

This equipment is intended for indoor use only. Do not install or operate this equipment in outdoor areas.

#### **Notice**

The reliability of the appliance can only be guaranteed when it is used properly. The appliance must always be operated within the limits and/or the operating conditions provided in this manual.

#### **Notice**

Avoid dropping any hard objects onto the equipment. Damages to the heating surface will shorten the life cycle of the equipment or incur high service costs.

#### **Notice—Models with Glass-Top**

##### **Use Only Induction Suitable Cookware**

Use only induction suitable cookware with proper sizes and made of proper material. The induction suitable cookware must be in good condition without any uneven, arched or partially detached bottoms.

Using unsuitable cookware can cause the appliance to fail prematurely, void your warranty, and incur high service costs.

**OPERATION SAFETY—PERSONAL PROTECTION**

**Notice**

Induction appliances are more powerful, heat up pans quicker than conventional cooking equipment. Your induction appliance needs to be operated and looked after in a different way than conventional cooking equipment.

Do not operate the equipment without reading this manual and understanding all safety requirements.

**⚠ DANGER**

If any part of the appliance is cracked or broken, **turn off the appliance and immediately disconnect the appliance from supply.** Only if it is possible and safe, disconnect the equipment from main power supply. Do not touch any parts inside the appliance.

Disconnect electric power at the main power disconnecter for all equipment being serviced.

Failure to disconnect the power at the main power supply could result in serious injury or death. The knob DOES NOT disconnect incoming power.

Contact an authorized service agency for assistance.

**⚠ DANGER**

Do not operate any appliance with a damaged or pinched cord or a damaged plug. All repairs must be performed by a qualified service company.

**⚠ DANGER**

Keep power cord AWAY from HEATED surfaces. DO NOT immerse power cord or plug in water.

**⚠ DANGER**

To avoid cardiac pacemaker malfunction, consult your physician or pacemaker manufacturer about effects of electromagnetic field on your pacemaker.

**⚠ DANGER**

Never stand, sit, or lean on the equipment! They are not designed to hold the weight of an adult, and may collapse or tip if misused in this manner.

**⚠ Caution**

**Short Cook Time**

Induction appliances heat up food faster than conventional holding equipment. To avoid overheating and burning, check the holding process frequently. Never leave the appliance unattended during operation.

**⚠ Caution**

Metallic objects are heated up very quickly when placed on the induction cook zone during operation. To avoid injury,

DO NOT place any objects such as closed cans, aluminum objects (aluminum foils), cutlery, jewelry, or watches on the appliance.

DO NOT place any object such as paper, cardboard, or cloth on the cooking surface, because this creates a fire hazard.

DO NOT place credit cards, phone cards, tapes, or any objects that are sensitive to magnetism on the appliance.

DO NOT use the appliance for storage.

DO NOT place any paper products, cooking utensils, cutlery, plastic vessels or food on the appliance.

DO NOT place metallic objects such as kitchen utensils, cutlery etc. on the holding surface within the holding zones since they could get hot.

**⚠ Caution**

Aluminum foil must not be used with induction appliances! Aluminum foil may ignite and cause a fire!

**Notice**

Do not use the cooktop for food preparation such as cutting and chopping.

**⚠ Warning**

Risk of burns from high temperatures. You may get burnt if you touch any of the parts during operation. Surfaces close to the cooking area including side panels may get hot enough to burn skin. Use extreme caution to avoid coming in contact with hot surfaces or hot grease. Wear personal protective equipment.

**⚠ Warning**

Take care when operating the appliance, as rings, watches and similar objects worn by the user could get hot when in close proximity to the holding surface.

**⚠ Warning**

During operation, it is possible that the floor around the unit become slippery. Wear suitable footwear and clean the floor if necessary.

**Holding with Induction Models****⚠ Warning****Never Leave An Empty Pan On Holdingtop**

Induction appliances heat up empty pans very quickly. Never operate the appliance with an empty pan. Do not pre-heat pan. Always put food products, water or oil into the pan before turning on the appliance. Failure to do so will result in irreparable damage.

**Notice****Broil-Dry Protection**

Holding zones are monitored by temperature sensors. The sensors can detect overheating at the base of a cooking pan.

When an overheated pan (overheated oil, empty pan) is detected, the appliance stops transferring energy to the pan immediately. You must turn off the appliance and let it cool down before re-starting the appliance.

**⚠ Caution****Do Not Touch Overheated Appliance**

To avoid burn injuries, do not touch the appliance when a pan is overheated and take all the necessary precautions when removing the overheated pan.

**⚠ Warning**

Steam can cause serious burns. Always wear some type of protective covering on your hands and arms when removing lids or pans from the appliance. Lift the lid or pan in a way that will direct escaping steam away from your face and body.

**⚠ Warning**

Never leave any pan during the cooking process unattended.

### Important Rules—Operation and Maintenance

Follow these simple rules to ensure reliable and repeatable performance of your induction equipment:

**1 Keep kitchen temperature below 40°C [104°F].**

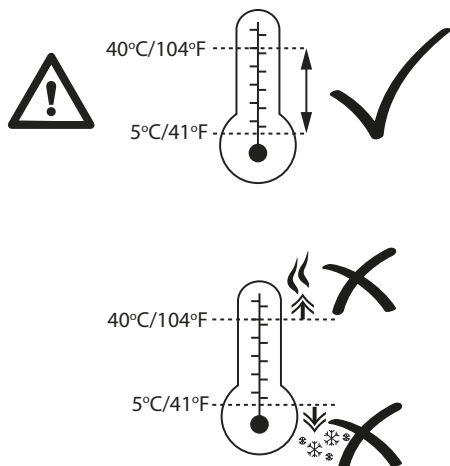

**3 Do not use dented pans because it will cause damages to the electronics.**

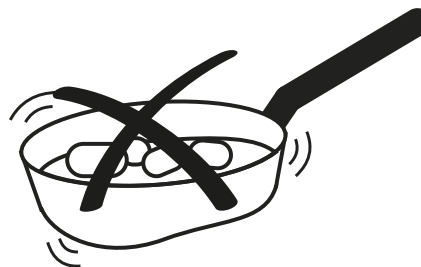

**2 Use only pans in a size suitable for the warming surface. Do not use oversized pans.**

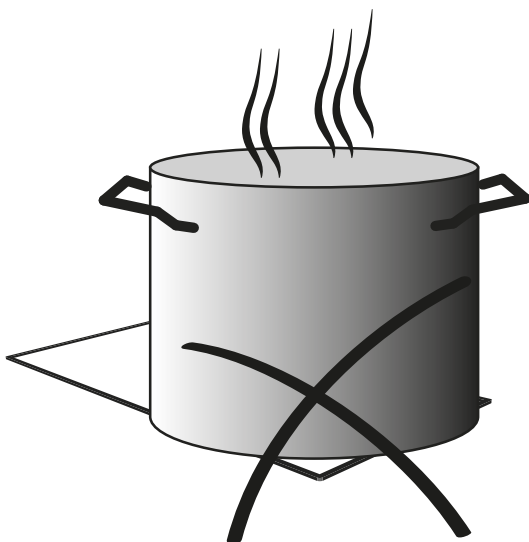



### Proper Induction Cookware

#### CONDITION

- Pans with layer separation (outward and inward bubbles), arching or partially detached bottoms must be replaced.
- When these pans are used, the sensors under the glass-top cannot detect temperature correctly. These pans will overheat the sensors and eventually will damage the sensors and the generator. (Below, examples of good and bad pans in cross-sections.)

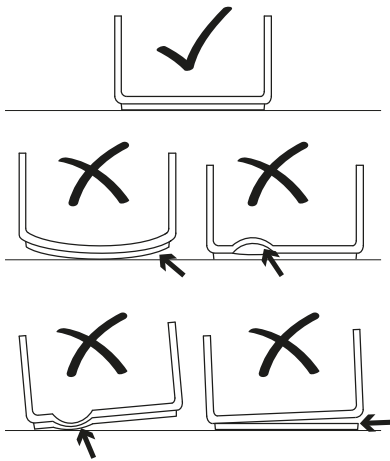

#### MATERIAL

- **USE** cookware made of **conductive and magnetic** materials. If the pan bottom attracts a magnet, the pan is suitable for induction cooking. Look for cookware that is labeled **suitable for induction** or with an induction compatible symbol.

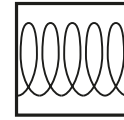

- **DO NOT USE** cookware made of aluminum, copper, glass or ceramics (unless it specifically is suitable for induction).
- NOTE—Steel inserts on bottom:

Cookware base inserted with areas of aluminum reduces the magnetic area for induction cooking. The appliance may supply less energy to the cookware or have difficulties in detecting the pan.

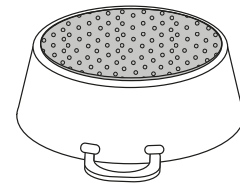

- NOTE—Non-magnetic cookware with a small magnetic base:

The exposed non-magnetic metal on the base may affect the induction field and subsequently, less energy may be supplied to the cookware.

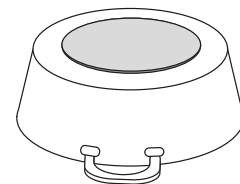

- NOTE - The bottom of the pan or holding container must touch the ceramic glass over its entire surface. Otherwise, the temperature can not be regulated accurately and the food can boil or the set temperature is not reached.

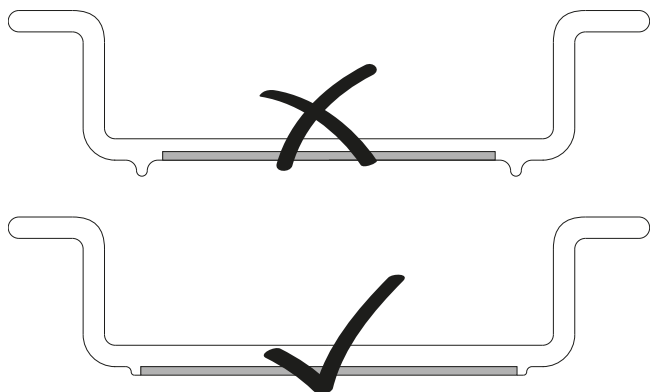

**SIZE OF PAN**

- MINIMUM SIZE:** The bottom of pan must have a minimum diameter of 12cm [5"]. Otherwise, the pan will not be heated. This is a safety feature such that the unit do not detect and heat up small metal objects, such as jewelery. NOTE: For personal safety, never place any small metallic objects on a cook zone.
- DO NOT USE OVERSIZED PAN!** The bottom of the pan must fit the glass. When a hot, oversized pan covers the silicone seal underneath, the heat from the pan may dry out the silicone overtime. When the silicone seal dries out and breaks, liquid can penetrate into the appliance and damage the electronics.

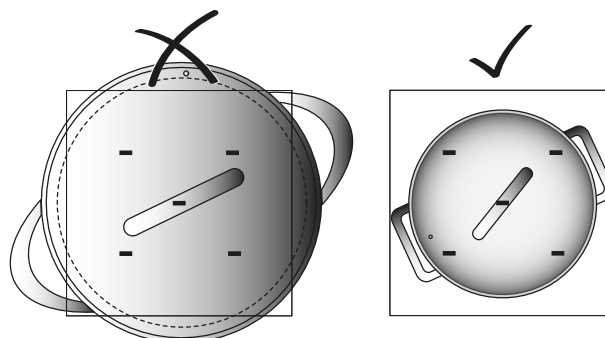

## Placing Pan On A Cook Zone

Each cook zone of our appliances is equipped with the latest RTCS® or RTCSmp® sensors. These sensors monitor temperature and cookware continuously in real time.

To obtain optimal results from the sensors, you must **always place pan in the center of the holding zone**. Otherwise, the bottom of the pan is heated unequally and the food inside the pan may burn.

The Hold-Line1-380 has markings on the Ceran glass. The marks show where the sensors are located. Note that the pans cover as many sensors as possible.

## Short overview Display and Operation

### Display

- Shows the temperature.
- Indicates when the operation is locked „LOCK“ and unlocked „UNL“.
- Indicates when the device is in standby mode „S“
- Indicates when the surface of the device is hot. „HOT“
- Indicates missing pan. „P\_F“
- Shows errors of the device.

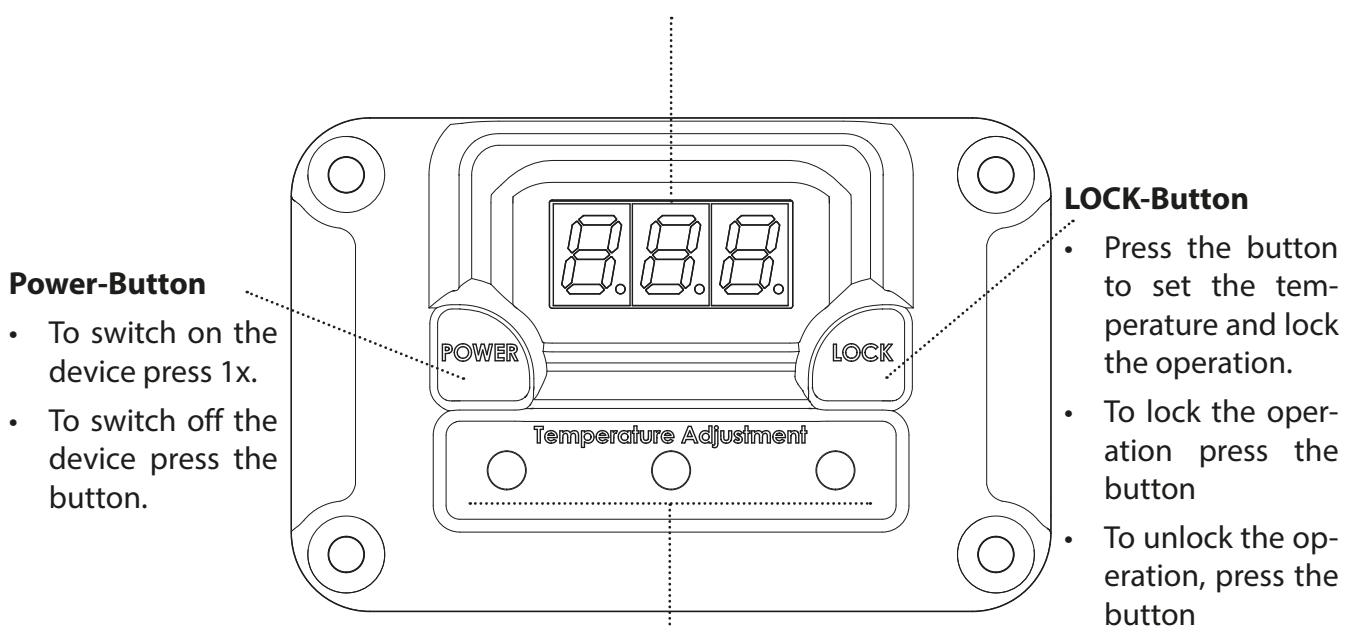

### Power-Button

- To switch on the device press 1x.
- To switch off the device press the button.

### LOCK-Button

- Press the button to set the temperature and lock the operation.
- To lock the operation press the button
- To unlock the operation, press the button

### Setting the set point temperature via buttons

- Press the mark to select the temperature.
- Left Button: 65°C / -1°C
- Center Button: 80°C
- Right Button: 93°C / +1°C
- After the beep: Press left button to increase and right button to decrease the temperature.

Please note that the buttons are made as touch buttons.

## Control

### TURN UNIT ON

Press the power button and then select the set point temperature.

### DISPLAY

- The indicator flashes when operator input is required.
- The display changes between the actual temperature and the set point temperature during the energy delivery (the target temperature is marked with a dot in the lower right corner).
- During energy delivery, the display changes between set point and actual temperature.

### SELECTION OF HOLDING TEMPERATURE AND LOCK / UNLOCK FUNCTION

1. Press one of the three buttons to select the start temperature. After 2 seconds the temperature is taken over. The appliance will now start to heat the cookware to the set temperature. The display changes between set point and actual temperature. The target temperature is marked with the dot in the lower right corner.



Set temperature

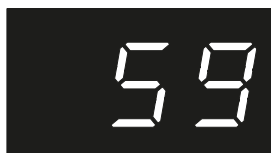

Actual temperature

2. With the outer temperature adjustment buttons, you can now increase or decrease the set point temperature in 1°C increments.
3. Press the Lock button so that the set temperature can not be adjusted. **LOC** will appear in the display.
4. To unlock the operation Press the Lock button again. It appears **UNL**. After unlocking, you can start again from step 1. If no entry is made within 2 seconds, the unit will auto-

atically go to step 2.

### TURN UNIT OFF

Press the power button to turn off.

When the power is off, **□** appears in the display..



If the keep warming zone is over 50°C **Hot** will appear in the display.



## Automatic Pan Detection

When a temperature or a power level is selected, the appliance supplies energy only when a pan is placed in the cook zone.

When you remove the pan from the cook zone, the appliance stops power output immediately. The power output resumes, when the pan is placed back on the cooking zone.

### Notice

Switch off the cook-top by means of the control. Do not rely on the Pan Detection as the ON-OFF control.

### Notice

Pan with a bottom diameter smaller than 12cm or 5" is not detected by the system.

If no pan is detected, a pans symbol appears in the display.



## When Appliance Is not in use

When the induction appliance is not in use, always turn off the appliance.

### Notice

Switch the appliance off if you take the hold-ware away for a while. This will prevent the heating process to start automatically and unintentionally when a pan is placed back on the heating area. If any person needs to use the induction appliance, he/she will have to turn the appliance ON intentionally.

## Decommissioning

Procedure in case the device is not needed for a long time.

1. Switch off the device on the knob.  
(See Section 3 Turning Off)
2. Disconnect the device from the mains.

## Section 4 Maintenance

### MAINTENANCE SAFETY—DISCLAIMER

#### DANGER

It is the responsibility of the equipment owner to perform a Personal Protective Equipment Hazard Assessment to ensure adequate protection during maintenance procedures.

#### Warning

A good maintenance of the appliance requires regular cleaning, care and servicing. The site-supervisor and the operator must ensure all components relevant to safety are in perfect working order at all times.

HINWEIS: Cleaning tools and supplies are not provided.

### DANGEROUS ELECTRICAL VOLTAGE

#### DANGER

Do not open the appliance. Maintenance and servicing work other than cleaning as described in this manual must be done by an authorized service personnel.

#### DANGER

If any part of the appliance is cracked or broken, **turn off the appliance and immediately disconnect the appliance from supply.** Only if it is possible and safe, disconnect the equipment from main power supply. Do not touch any parts inside the appliance.

Disconnect electric power at the main power disconnect for all equipment being serviced.

Failure to disconnect the power at the main power supply disconnect could result in serious injury or death. The knob DOES NOT disconnect incoming power.

Contact an authorized service agency for assistance.

### MAINTENANCE SAFETY—CLEANING

#### Warning

Never use a high-pressure water jet for cleaning or hose down or flood interior or exterior of the equipment with water. Ensure that no liquid can enter into the equipment.

#### Warning

Allow heated equipment / glass surface to cool down before attempting to clean, service or move.

#### Warning

When cleaning the exterior, care should be taken to avoid front power switch and the electrical cords. Keep water and cleaning solutions away from these parts.

#### Caution

Do not use caustic cleaners on any part of the equipment. Use mild, non abrasive soaps or detergents, applied with a sponge or soft cloth.

#### Caution

Ensure to remove all residues of cleaning agents from the holding surfaces. Use a clean moist cloth to wipe off any surfaces.

#### Caution

Using commercial cleaning fluids or chemicals: Read the directions for use and precautionary statements before use. Pay attention to the concentration of cleaner and the length of time the cleaner remains on the food-contact surfaces or equipment surfaces.

**Notice**

**Inspect and Clean Fresh Air Intake Filter**

We strongly recommend using air intake filters in all installations to protect the equipment from grease particles. A dirty, blocked air intake filter blocks the air vent and can cause damages to the electronic components. Inspect, clean or replace the air intake filters at least once a week or as often as necessary.

**⚠ Warning**

**Inspect Silicone Seal**

When the silicone seal is broken, water penetration could cause the appliance to fail, and any malfunction could cause personal harm.

**PERSONAL PROTECTION**

**⚠ DANGER**

All utilities (gas, electric, water and steam) must be OFF to all equipment and locked out of operation according to national/regional regulations, as well as company approved practices during installation, maintenance and servicing. Always allow appliance to cool.

**⚠ DANGER**

Use appropriate safety equipment during installation, maintenance and servicing.

**⚠ DANGER**

Never stand, sit, or lean on the equipment! They are not designed to hold the weight of an adult, and may collapse or tip if misused in this manner.

**⚠ DANGER**

To avoid cardiac pacemaker malfunction, consult your physician or pacemaker manufacture about effects of electromagnetic field on your pacemaker.

**⚠ DANGER**

Replace defective power cables immediately by an authorized service agency.

**⚠ Warning**

Markings and warning labels mounted directly on the equipment must be observed at all times and kept in a fully legible condition.

**⚠ Warning**

Risk of burns from high temperatures. You may get burnt if you touch any of the parts during operation. Surfaces close to the cooking area including side panels may get hot enough to burn skin. Use extreme caution to avoid coming in contact with hot surfaces or hot grease. Wear personal protective equipment.

**⚠ Caution**

Use caution when handling the Device. Metal edges of all equipment can be sharp.



## Daily Cleaning and Maintenance

### GLASS CLEANING



**HINWEIS:** The cleaning of glass is identical to cleaning other similar glass surfaces. You may use any regular glass cleaning products available from a hardware store.

You may use a razor blade scraper or a non-scratching sponge to remove tough residues. When scraping, place your razor blade scraper at an angle of about 20° to 30° from the glass. Then wipe clean the glass with a cleaning product.

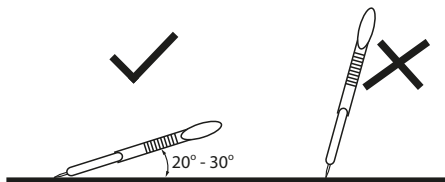

### VISUAL INSPECTION OF SILICONE SEAL

Inspect the silicone seal around the glass perimeter. Call for service immediately if you notice:

- Cracks on the silicone seal.
- The silicone seal comes away from the glass/housing or moves when you press down on the seal.

### Yearly Maintenance

**Best Practice:** Have the induction appliance examined once a year by an authorized technician.

#### General Maintenance Tips:

- Inspect all induction cookware to ensure proper condition.
- Have an authorized technician to inspect and ensure that:
  - All ventilation fans are working properly.
  - No grease built-up around the equipment.

## Section 5 Troubleshooting

### DANGEROUS ELECTRICAL VOLTAGE

#### **⚠ DANGER**

If any part of the appliance is cracked or broken, **turn off the appliance and immediately disconnect the appliance from supply.** Only if it is possible and safe, disconnect the equipment from main power supply. Do not touch any parts inside the appliance.

Disconnect electric power at the main power disconnect for all equipment being serviced.

Failure to disconnect the power at the main power supply disconnect could result in serious injury or death. The power switch DOES NOT disconnect all incoming power.

Contact an authorized service agency for assistance.

#### **⚠ DANGER**

Do not open the appliance. Maintenance and servicing work other than cleaning as described in this manual must be done by an authorized service personnel.

#### **⚠ Warning**

Markings and warning labels mounted directly on the equipment must be observed at all times and kept in a fully legible condition.

NOTE: If a problem arises during operation of your induction appliance, follow the Troubleshooting Charts (Page 37 - 39) before calling service. Routine adjustments and maintenance procedures are not covered by the warranty.

### Common Problems

One or more of the following conditions may affect the function or cause the induction equipment to fail:

- Using unsuitable cookware such as non-induction pans, oversized pans, or damaged

pans.

- High ambient temperature.
- Inadequate ventilation causing hot air to re-enter through the air intake slots.
- Dirty air intake filter.
- Empty pan is left on the hob when the appliance is ON.

### Symptoms

- When a malfunction occurs, the appliance may be in one of the following states:
- The appliance switches off immediately.
- The appliance continues to operate in a power reduction mode.
- The appliance continues to operate normally.
- NOTE:

The cooling fan starts when the ambient temperature in the control area exceeds 55°C [130°F].

If the heat sink temperature is higher than 70°C [160°F], the controller automatically reduces power to keep the appliance in normal operating conditions.

---

## Avoiding Danger in case of accidents or malfunctions

To avoid hazards in the event of a malfunction or accident related to the device, proceed as follows.

1. Disconnect the power supply from the circuit breaker provided for the device.
2. Disconnect the mains plug of the affected device to prevent it from being switched on again.

**⚠ DANGER**

If the plug is not safely accessible, the device must be switched off at the main circuit breaker.

### Troubleshooting Without Error Code

Symptom	Possible Cause	Action
Pan does not heat up on glass-top. Digital display is OFF (dark).	No power supply.	Check incoming power supply (Example, power cable plugged into the socket). Check kitchen main fuse box.
	Defective unit.	Only if possible and safe, disconnect the appliance from the power supply. Contact an authorized service agency. (1)
Pan does not heat up and no pan symbol is on.	Pan is too small.	Use a suitable pan with bottom diameter larger than 12cm[5"].
	Pan is not placed in the center of the hob; pan is not detected by sensor. (2)	Move the pan to the center of the hob.
Poor heating	Unsuitable pan.	Select only induction-ready cookware.
	Defective unit.	Only if possible and safe, disconnect the appliance from the power supply. Contact an authorized service agency. (1)
	Air-cooling system is obstructed.	Verify that air vents are not obstructed. Ensure the fresh air filter is clean.
	Unsuitable pan.	Select various induction-ready cookware for induction cooking. Then compare the results.
	Ambient temperature is too high. The cooling system is not able to keep the appliance in normal operating conditions.	Verify that no hot air is taken in by the fan. Reduce the ambient temperature. The intake air temperature must be lower than 40°C [104°F].
	Defective unit.	Only if possible and safe, disconnect the appliance from the power supply. Contact an authorized service agency. (1)
	Defective operation unit.	Only if possible and safe, disconnect the appliance from the power supply. Contact an authorized service agency. (1)
	Pan detection function is defective.	Only if possible and safe, disconnect the appliance from the power supply. Contact an authorized service agency. (1)
	The operation does not respond to any input.	Only if possible and safe, disconnect the appliance from the power supply. Contact an authorized service agency. (1)
	Small metallic objects (e.g. spoon) are heated up in the cook zone.	Only if possible and safe, disconnect the appliance from the power supply. Contact an authorized service agency. (1)

- (1) **▲ DANGER** If the plug is not safely accessible, the device must be switched off at the main circuit breaker.
- (2) The appliance switches off immediately.

**Troubleshooting — Error Code**

Error Code (Display)	Problem	Action
	Normal Operation.	Normal Operation.
E01	Unsuitable induction cooking pan. Internal wiring/coil connection malfunction. (2)	Check pan material. Contact an authorized service agency.
E02	Unsuitable induction cooking pan. Coil overcurrent. (2)	Check pan material. Contact an authorized service agency.
E03	Air-cooling system obstructed. Fan malfunction. Heat sink overheated. (2)	Let appliance cool down. Verify that air vents are not obstructed. Check and clean air filter. Contact an authorized service agency.
E04	Overheated cook zone. Overheated pan detected. Sensor failure.	Let appliance and/or pan cool down. Check pan material. Verify that air vents are not obstructed. Check and clean air filter. Contact an authorized service agency.
E41, E42, E43, E44, E45, E46	Overheated or defective sensor. (2)	Check and clean air filter. Contact an authorized service agency.
E06, E30	Ambient temperature too high (the cooling system is not able to keep the induction appliance in normal operating conditions). Internal component overheated. (2)	Let appliance cool down. Verify that air vents are not obstructed. Check and clean air filter. Verify that no hot air is taken in by the fan. Reduce the ambient temperature. The intake air temperature must be lower than 40°C [104°F]. Contact an authorized service agency.
E08	Over- or undervoltage.	Contact an authorized service agency.
E10	Communication problem between generator and operation unit.	Check the connection between generator and control unit. Contact an authorized service agency.
E12 + E20	Devices over temperature or overheated.	Let appliance cool down. Verify that air vents are not obstructed. Contact an authorized service agency.
E29	Generator component failure. (2)	Contact an authorized service agency.

Error Code (Display)	Problem	Action
E47	Warning from overheated pan / cooking empty sensor or coil connection failed. (2)	Let equipment / pan cool down. Check pan material. Check food in the pan or empty pan.
E21	Sensor error from heat sink. Ambient temperature beyond normal operating range. (2)	Verify that air vents are not obstructed. Check air filter. Reduce ambient temperature. Contact an authorized service agency.
E24	Sensor error from CPU. Board overheated. Ambient temperature beyond normal operating range. (2)	Verify that air vents are not obstructed. Check air filter. Reduce ambient temperature. Contact an authorized service agency.

- (1) **▲ DANGER** If the plug is not safely accessible, the device must be switched off at the main circuit breaker.
- (2) The appliance switches off immediately.



**WELBILT®**  
*Bringing innovation to the table*

**WWW.WELBILT.COM**

Welbilt provides the world's top chefs, and premier chain operators or growing independents with industry leading equipment and solutions. Our cutting-edge designs and lean manufacturing tactics are powered by deep knowledge, operator insights, and culinary expertise.

All of our products are backed by KitchenCare® – our aftermarket, repair, and parts service.

- ▶ CLEVELAND
- ▶ CONVOTHERM®
- ▶ DELFIELD®
- ▶ FITKITCHEN™
- ▶ FRYMASTER®
- ▶ GARLAND
- ▶ KOLPAK®
- ▶ LINCOLN
- ▶ MANITOWOC®
- ▶ MERCOC®
- ▶ MERRYCHEF®
- ▶ MULTIPLEX®